



# Ultraseal<sup>TM</sup> LITE

THE INTUITIVE, SEMI-AUTOMATIC HEAT SEALER

Porvair Sciences Ultraseal<sup>TM</sup> LITE is the effortless, lightweight heat sealer designed to tightly seal polypropylene, polyethylene and polystyrene microplates and glass tubes. Ideal for low to medium throughput laboratories, this compact and user-friendly instrument is fully electrical with no gas inputs required and can seal up to 6 plates per minute with a high degree of integrity and reproducibility. The Ultraseal<sup>TM</sup> LITE is intuitively designed to auto-detect and adjust in response to a wide range of plate heights thereby eliminating the need of spacers and reducing the risk of cross-contamination in standard microplates sealing.

## Key Features

- Simple slide & seal operation
- Seal up to 6 plates per minute
- Fully electric for reliable sealing and optimal programming
- Auto-adjusting sensors for different plate heights (no spacers required)
- Suitable for polypropylene, polyethylene and polystyrene plates
- Ability to seal PCR plates

## Slide and Seal

Pre-cut sheets of surface modified aluminium or plastic film (~78 mm x 128 mm) are placed on the plate surface and the sliding drawer pushed closed to initiate sealing program. There is no need for plate height spacing as the Ultraseal<sup>TM</sup> LITE has ability to seal from 9 mm to 48 mm tall plates. In under 10 seconds, plates are tightly sealed, automatically ejected and ready for downstream applications such as storage and transportation.

## Smooth Operation

Constant time and pressure is key to obtaining consistent and a tight seal each and every time. The system operation is designed to efficiently and accurately align a heat-activated sealing medium to a microplate or tube rack top surface. Using the touch screen control pad, heat and time based variables can be easily programmed to optimise the quality, strength and integrity of sealing. The Ultraseal<sup>TM</sup> LITE has a temperature range of up to 200°C to suit a wide range of sealing films and foils. *Check out our sealing guidelines for microplate types below.*

## Product Features

Plate Height Range	9 mm - 48 mm
Weight	9 kg
Temperature Range	up to 200°C
SBS Format	Yes
Well Numbers	24-, 48-, 96- and 384-well
Compressed Air Required	No
Spacers Required	No
Sealing Time	up to 10 sec/plate

## Product Compatibility

Polystyrene Microplates	Yes
Polypropylene Microplates	Yes
Polyethylene Microplates	Yes
Foil Seals	Yes
Optical Seals	Yes
Gas Permeable Seals	Yes
Manual Pre-cut and Apply Seals	Yes

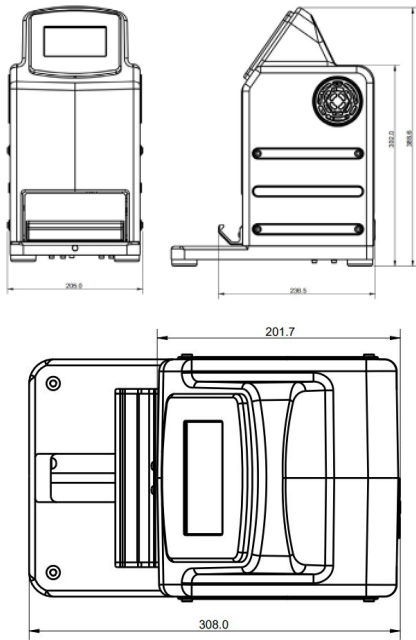

## Technical Specifications

Power Supply	115/230 VAC 50/60 Hz
Power Consumption	500 Watts Nominal
Fuse Rating	5 Amp Anti-surge (T5AH 250V)
Internal Heaters	4 x 100 Watts (Sealing Plate)
Dimensions	195 mm (w) x 300 mm (d) x 385 mm (h)
Protection	IP20

## Sealing Guidelines

Plate Material	Temperature Setting (°C)	Time Setting (seconds)
Polystyrene	145-165	2-5
Polypropylene	150-175	2-5
Polyethylene	150-170	2-5

## Ordering Information

Product #	Description
500091	Ultraseal™ LITE, the adaptable semi-automatic microplate sealer.

## Contact Information

### EU/RoW Enquiries

Email: [int.sales@porvairsciences.com](mailto:int.sales@porvairsciences.com)

### USA Enquiries

Email: [info@jgfinneran.com](mailto:info@jgfinneran.com)



# Heat Sealing Films and Foils

Explore the diverse range of sheet-form, sealing films available for a wide range of laboratory applications. All compatible with the Ultraseal™ LITE.

Format: Sheets (125 mm x 78 mm)

Pack Size: 100 per Pack



Product	Product #	Description	Appearance	Solvent Resistance	Temp Range (°C)	Gas Permeable	Peelable	Pierceable	Plate Compatibility	Applications
Clear Seal Peel	SF01078LS	Clear, peelable film for wide range of plate material	Optically clear film	Moderate	-80 to 80	No	Yes	No	PP, PE, PS, COC	qPCR, short-term compound storage
	SF01078SS (Sterile)									
Clear Seal Weld	SF02078LS	Clear, non-pierceable permanent seal with high solvent resistance	Optically clear film	Good, DMSO Resistant	-80 to 110	No	No	No	PP	Optical applications, water bath, PCR, use of DMSO & other solvents
	SF02078SS (Sterile)									
Clear Seal Pierce	SF03078LS (Sterile)	Clear, pierceable permanent film	Optically clear film	Moderate	-80 to 80, or 110 with pressurised PCR-heated lids	No	No	Yes	PP, PE, PS, COC	ABI 3730 PCR sequencer
	SF03078SS									
Peel Seal Foil	SF04078LS (Sterile)	Non-pierceable, permanent foil	Foil (white laminate)	Moderate	-80 to 110	No	Yes	No	PP, PE, COC	PCR, good liquid barrier, low temp short-term compound storage, re-sealable
	SF04078SS (Sterile)									
Peel Seal DMSO Foil	SF05078LS	Non-pierceable, peelable foil with high solvent resistance	Foil	Excellent	-80 to 80	No	Yes	No	PP, PE, COC	Compound storage at low & ambient temperature, with DMSO & other solvents
	SF05078SS (Sterile)									
Pierce Seal Foil	SF06078LS	Pierceable, permanent foil with high temperature stability	Foil with green dashed line	Good, DMSO Resistant	-20 to 120	No	No	Yes	PP, PS	PCR, compound storage, sample shipping, can seal over existing seal
	SF06078SS (Sterile)									
Pierce Seal Foil PS	SF07078LS	Pierceable and peelable foil with high temperature stability	Foil with solid green line	Good, DMSO Resistant	-20 to 110	No	Yes	Yes (on PS plates)	PP, PS	PCR, low temp compound storage, short term ambient temp storage, re-sealable
	SF07078SS (Sterile)									
Therm Seal Foil	SF08078LS	Thermal cyclor foil for wider temperature range for PP & PS plates	Foil	Good, DMSO Resistant	-200 to 110	No	Yes	No	PP, PS	PCR, water bath thermo cyclers, long term compound storage of hazardous materials
	SF08078SS (Sterile)									

Product	Product # (Non-Sterile)	Description	Appearance	Solvent Resistance	Temp Range (°C)	Gas Permeable	Peelable	Pierceable	Plate Compatibility	Applications
Gas Perm Seal	SF10078LS	Gas permeable, pierceable and peelable seal for cell culture applications	Non-woven, cream	None	-20 to 80	Yes, impervious to fluids	Yes	Yes	PP, PS	Short-term incubation, agriculture & seed storage, cell culture, for use in autoclaves
	SF10078SS (Sterile)									
Clear Seal Perf	SF11078LS	Clear, peelable and perforated for gas permeable applications	Transparent perforated film	Moderate	-80 to 80	Yes	Yes	No	PP, PE, PS, COC	Short term incubation, seed & insect storage, cell culture, can be resealed for transport
	SF11078SS (Sterile)									
Gas Perm Seal 2	SF13078LS	Pierceable, peelable and gas permeable seal	Grid effect coated paper	None	-20 to 80	Yes	Yes	Yes	PP, PS, COC	Short term incubation, agriculture and seed storage, insect storage and cell culture
	SF13078SS (Sterile)									
Peel Seal Foil Super	SF14078LS	Non-pierceable, peelable seal with high resistance to DMSO	Foil (White laminate)	Good, DMSO Resistant	-80 to 110	No	Yes	No	PP, PE, PS, COC	PCR, low temperature, short term compound storage, short-term room temperature compound storage
	SF14078SS (Sterile)									

### Contact Information

EU/RoW Enquiries

Email: [int.sales@porvairsciences.com](mailto:int.sales@porvairsciences.com)

USA Enquiries

Email: [info@jgfinneran.com](mailto:info@jgfinneran.com)



Porvair Sciences, together with JG Finneran and Porvair Kbiosystems are global manufacturers of consumables and instruments for life science and analytical workflows. From microplate technologies, glass vials, assay kits to automated laboratory equipment, the group is committed to equipping customers with high quality products for improved analysis and increased productivity to accelerate scientific discovery with integrity.

