

MagCore[®] Automated Nucleic Acid Extractor

MagCore[®] Automated Nucleic Acid Extractor Overview



Process Monitoring through your Smartphone

MagCore[®] Plus II

Spectrophotometer Built-in

MagCore[®] Super

NA Extraction and PCR Set-up

MagCore[®] EDA

■ Standard □ Optional

16
Sample

1- 16 Samples

48
Sample

1- 48 Samples



Spectrophotometer



Touch Screen



UV Decontamination



Barcode Scanner



Thermo Printer



Built-in Programs
(Upgradeable via USB ports, Plug&Play)



USB Output
(USB flash drive not provided)



Progress Monitoring
(Wireless)



LIMS (Laboratory Information Management System)

HEPA Decontamination

Extraction +PCR set up

PCR set up



MagCore® Automated Nucleic Acid Extractors will keep you ahead in Life Science



MagCore® Extractor System is a simple, fast and cost-effective instrument for automated purification of nucleic acids from a diverse range of sample sources. Featuring pre-programmed protocols and our unique magnetic-bead technology, MagCore System delivers efficient and consistent nucleic acid purification.

MagCore® Extractors are bench-top instruments ensuring efficient and cross-contamination free isolation of DNA/RNA. Built-in UV lamps allow to easily and efficiently decontaminate the instruments after run.

Flexibility

MagCore® Automated Extraction System allows you to save time without sacrificing consistency and purity. You can use one instrument to purify DNA and RNA from a broad variety of sample types: from blood to mouse tails and almost everything in between.

Ease Of Use

You will be provided with everything you need to run purifications, including pre-filled cartridges, specialized disposable tips and tubes. With the user-friendly interface and our user manuals, you are guaranteed to operate with ease.

Safety

MagCore® Automated Extraction System helps minimize cross-contamination by limiting hands-on procedures and turnaround time.

MagCore® System speeds the front-end processing, enabling you to do more tests in less time. And the Instrument is compact, so it can virtually fit into any lab.

Built-in Programs

All of our MagCore Extractor models have built-in protocols for all of the kits we offer. Simply run the protocol by selecting the 3-digit code printed on the kit of interest.

Free upgrade of software and protocols can be downloaded from our website (www.rbcbioscience.com) and uploaded through the instrument RS232/USB ports.

Diverse Sample Purification

We offer extraction kits designed for Blood, Plasma, Cell, Tissue, FFPE Tissue and Plant samples, to fit all your research needs.

Competitive Price and Small Footprint

Other Features

Automatic Optical Density Measurement

- Built-in spectrophotometer provides O.D. A_{260} and A_{280} measurement of individual samples. (O.D. detection range: ABS < 6.)
- A_{320} Normalization
- Disposable cuvettes.

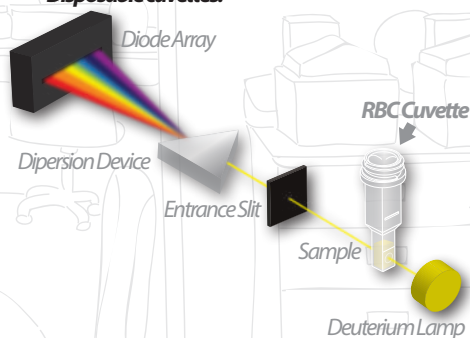

Thermo Printer and Barcode Scanner

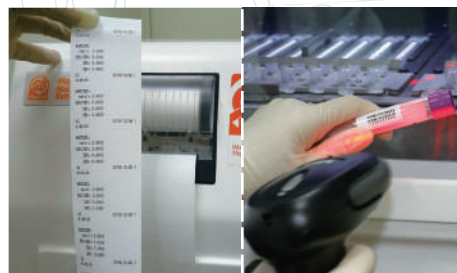

Progress Monitoring



Laboratory Information Management System (LIMS)



Easy To Use

Apply samples to instrument



Load Accessories

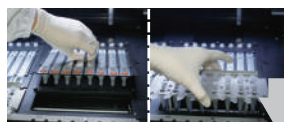

Select the number of the cartridge

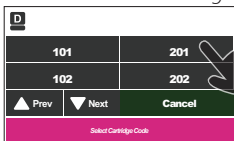

Select Sample Volume

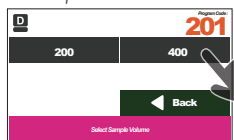

Push Start



A Beep Sound can be heard after protocol is completed

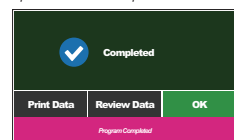

FDA (10055336) registered and CE-IVD certified (Instruments & Reagents)
Manufactured in accordance with quality system requirements that comply with ISO 13485 standards and QSR

RBC Bioscience Corp.
www.rbcbioscience.com
info@rbcbioscience.com

MagCore® Nudeic Acid Extraction Kits



MagCore® Automated Nudeic Acid Kits Selection Guide



		Cat.No. 24 preps	Cat.No. 36 preps	Cat.No. 72 preps	Cat.No. 96 preps	Whole Blood	Buffy Coat	Plasma/Serum	Cell-free body fluids	Urine	Free circulating DNA	Amniotic Fluid	Cultured Cells	Animal Tissue	Plant Tissue	Bacteria/Sputum	Swab	FFPE	Stool	Forensic Specimens	PCR Product		
NGS	701 MagCore® NGS-Clean up Kit		MNC-01		MNC-02																	■	
	101 MagCore® Genomic DNA Whole Blood Kit (Speedy installation)		MGB400-01		MGB400-02	■	■																
	102 MagCore® Genomic DNA Whole Blood Kit		MGB400-03		MGB400-04	■	■																
	104 MagCore® Genomic DNA Large Volume Whole Blood Kit (1.2 ml)				MGB1200	■																	
	105 MagCore® Plasma DNA Extraction Kit (1.2 ml)				MPD1200			■	■		■												
Genomic DNA	115 MagCore® Circulating DNA large volume kit (3-4 ml)	MPD4000-01			MPD4000-03			■	■		■												
	106 MagCore® Genomic DNA Whole Blood Kit (For Genotyping)		MGB400-07		MGB400-08	■																	
	110 MagCore® Cultured Cells DNA Kit		MCC-01		MCC-02							■	■										
	301 MagCore® Genomic DNA Plant Kit		MGP-01		MGP-02										■								
	401 MagCore® Genomic DNA Tissue Kit		MGT-01		MGT-02									■						■	■	■	■
	405 MagCore® Genomic DNA FFPE One-Step Kit		MGF-01		MGF-03																■		
	406 MagCore® Forensic DNA Direct Kit				MFC-03																		■
	502 MagCore® Genomic DNA Bacterial Kit		MBB-01		MBB-02												■						
	504 MagCore® Gut Microbiome DNA Kit		MGM-01		MGM-03																		■
	Viral Nucleic Acids	202 MagCore® Viral Nucleic Acid Extraction Kit (Low PCR Inhibition)		MVN400-03		MVN400-04			■	■	■												■
203 MagCore® Viral nucleic acid extraction kit (high sensitivity)			MVN400-05		MVN400-06			■	■	■												■	
210 MagCore® Viral Nucleic Acid Large Volume Extraction Kit (2.4 ml)					MVN2400			■	■	■												■	
211 MagCore® Viral Nucleic Acid Large Volume Extraction Kit (1.2 ml)					MVN1200			■	■	■												■	
Total RNA	605 MagCore® Total RNA FFPE One-step Kit	MRF-01		MRF-01																		■	
	620 MagCore® miRNA Extraction Kit	MMR-01		MMR-02	MMR-02			■	■														
	631 MagCore® triXact RNA Kit	MRX-01		MRX-03		■							■	■	■								

MagCore® Cartridge Design and Extraction Principle



MagCore® cartridges include all reagents needed for purifications, no additional handling is necessary. We minimize any possible contamination and spillage with an automated piercing step for our pre-sealed cartridges. RBC patented Heating Well and Separation Well in the cartridge provide a strong circular force to ensure efficient binding and washing during the extraction procedure.

MagCore® Nucleic Acid Extraction Kits contain all reagents and consumables needed for 36, 72 or 96 nucleic acid isolation reactions. The consumables consist of reagent cartridges, individually packaged tip sets, sample tubes and elution tubes.

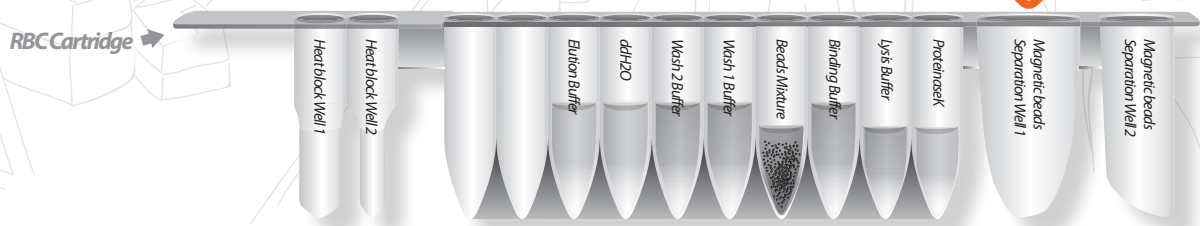
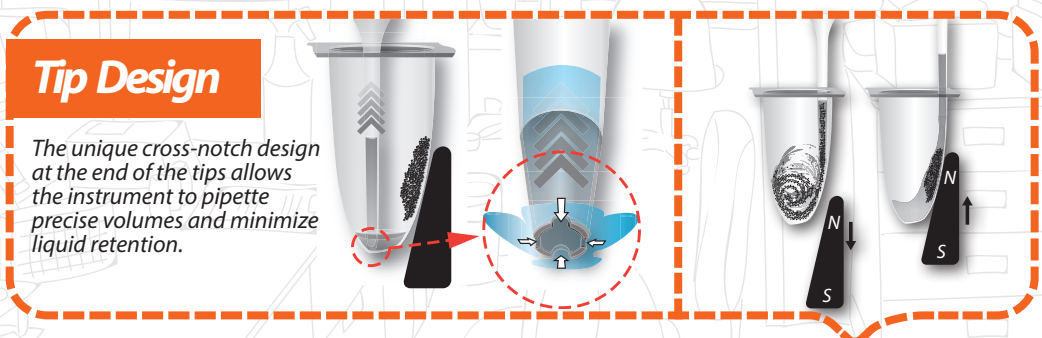

Each cartridge has 14 positions available with 10 sealed wells and 2 heating chambers.

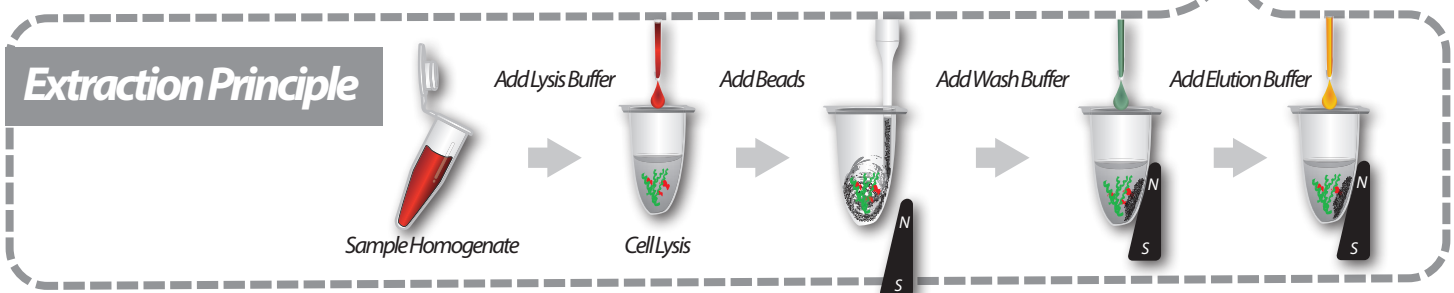

MagCore® Worldwide Patented Magnetic Beads

Our design: multiple core inside, cellulose coating.

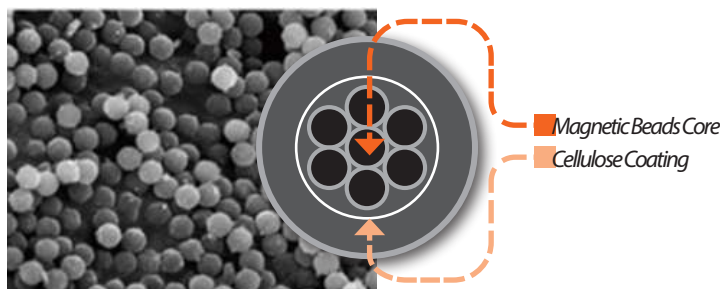

Particle range	~20µm (in water)
VSM	~40emu/g
Cellulose w%	~50%
Core size	~150nm
Core VSM	~80emu/g
Core material	Fe ₃ O ₄
Bead Binding capacity	1 mg beads bind ~300µg Calfthymus DNA ~350µg human placenta DNA



FDA (10055336) registered and CE-IVD certified (Instruments & Reagents)
Manufactured in accordance with quality system requirements that comply with ISO 13485 standards and QSR



MagCore[®] Automated Nucleic Acid Extractor

Full traceability and mobile monitoring
on your smartphone

MagCore[®] Plus II



MagCore[®] Plus II is the newest robotic bench-top workstation for a fast and high-yield nucleic acid purification from virtually all molecular diagnostic, biological, clinical and forensic sample types. With small footprint, light weight, user friendly interface, and a broad range of entirely built-in programs with free upgrades, 1-16 samples can be isolated simultaneously at your fingertip. The instrument simplifies your daily routine providing full traceability of kits and samples, through real-time mobile monitoring and a complete report that can be downloaded on a computer at the end of each run.



Worldwide Patented Magnetic Beads

Cellulose-coated magnetic beads, coupled with our patented binding and separation technology, guarantee high quality extracts.



Ideal for both DNA/RNA extraction

Built-in protocols are created for extracting nucleic acids from a wide range of samples, including whole blood, plasma (circulating free nucleic acid), tissue, bacteria, virus, plant and forensic.



Throughput up to 16 samples per run

From cartridge piercing to final eluate, all steps are performed by the instrument, that allows running 1 to 16 samples at one time, for a time-saving and flexible performance.



Full traceability of the samples and kits

A report in .csv format is generated at the end of each run and contains all relevant data: user's name, sample and kit barcode, protocol number, sample and elution volume, start and end time. The file, opened on a computer, can be subsequently processed by a LIMS.



Real-Time Mobile Monitoring

During the run, the instrument HMI can be accessed via Wi-Fi from your smartphone/tablet through our App, to see real-time information about the run processing status, remaining time and errors. Android and iOS compatible.



UV Decontamination

The equipped UV lamp minimizes the risk of cross-contamination and ensures user and product safety.



Built-in Programs (Upgradeable via USB ports, Plug&Play)

MagCore[®] Plus II features built-in protocols for all the extraction kits we offer and is equipped with a USB port for free protocol and software upgrades.



Barcode Scanner

For sample and kit tracking and monitoring and an easier organization of the test results.

Easy To Use

Load Samples And Install Accessories



Select User and Scan Barcodes:

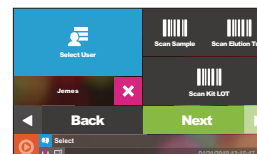

Select the code of the cartridge.

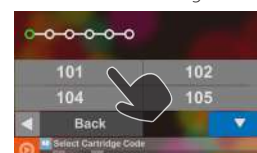

Select Sample Volume And Eluate Volume

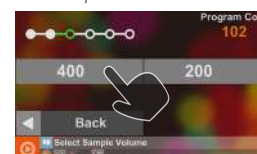

Press Start



A Beep Sound can be heard when the program completes.

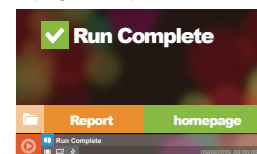

Open the run report on your computer

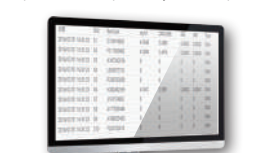

Same throughput, smaller size

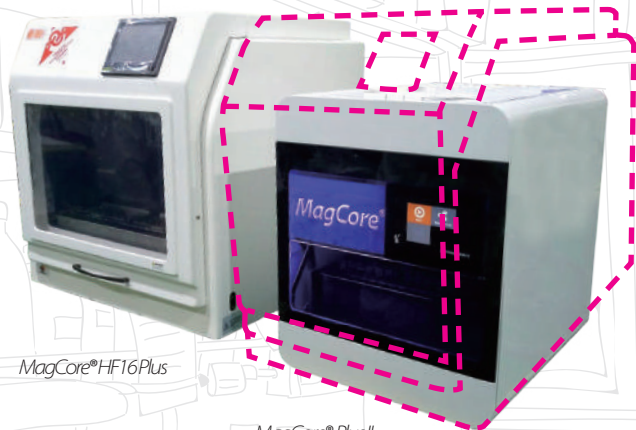

Barcode Scanner



Laboratory Information Management System (LIMS)
Unidirectional LIMS device, Ethernet cable



Cartridge Design and Extraction Principle

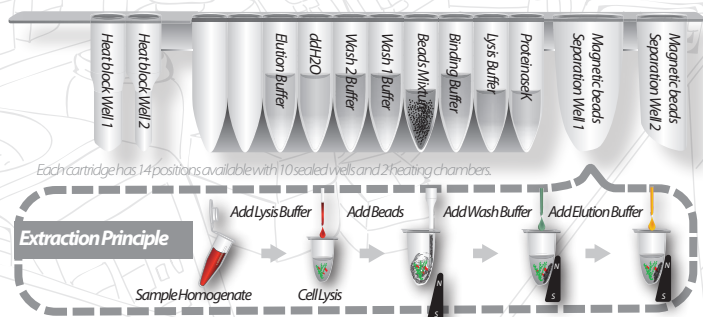

Specification

Model	Plus II
System Method	Cellulose coated magnetic beads
System Components	<ol style="list-style-type: none"> Pipetting Unit: X and Y-axis movement for sample transfer and dispense. PLC module, HMI and Driver main board embedded in UV Light: power 8w, life duration 11,000hrs Heating Block: RT-90°C Display Screen: 7-inch color touch panel Accessories: T-racks, cartridge racks, barcode scanner, waste box
Power Supply	Voltage: AC 100V~240V; Frequency: 50/60Hz
Dimension	W523 x D602 x H605 (mm) / W21 x D23.7 x H23.8 (inches)
Net Weight	70kg / 154.35lbs

Mobile Monitoring with Android and iOS App

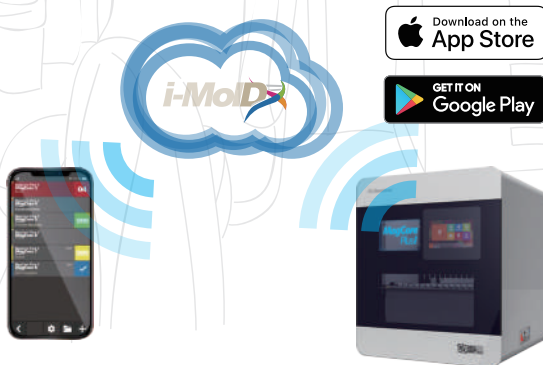

Operating Parameters

Processing Capacity	1-16 samples per batch
Processing Time	30-90 minutes (depends on sample type and method)
Sample Volume	200 µl / 400 µl / 1,200 µl / 4ml * depending on the program.
Elution Volume	30 µl / 40 µl / 60 µl / 100 µl / 150 µl / 200 µl * depending on the program.
Yield	Average 6 µg Genomic DNA from 200 µl human whole blood
Purity	DNA: OD ₂₆₀ /OD ₂₈₀ ratio 1.8 ± 0.1 RNA: OD ₂₆₀ /OD ₂₈₀ ratio 2.0 ± 0.2
Pipetting Accuracy	30-60 µl 20%; 60-100 µl 10%; 100-1000 µl 4%

Operating Environment

Temperatures allowed during transportation, storage, and packaging	15°C-35°C
Temperatures allowed during operation	18°C-30°C
Pollution Degree	Level 2



FDA (10055336) registered and CE-IVD certified (Instruments & Reagents)
Manufactured in accordance with quality system requirements that comply with ISO 13485 standards and QSR



MagCore[®] Automated Nucleic Acid Extractor

Automatic Extraction and Smart PCR Setup

MagCore[®] EDA



MagCore[®] EDA system is new generation instrument for nucleic acid extraction and PCR setup pre-treatment. MagCore[®] EDA can process up to 48 samples (in batches of 24), and has a built-in spectrophotometer which makes it a complete solution to increase laboratory efficiency and simplify the workflow. Users can benefit from automatic purification, OD values retrieval, high NA concentration in final elute and compatibility with LIMS.

using MagCore extraction kits, MagCore[®] EDA offers consistent, reliable DNA or RNA extraction in 30–120 minutes, depending on the sample type.

Worldwide Patented Magnetic Beads

Cellulose-coated magnetic beads, coupled with our patented binding and separation technology, guarantee high quality extracts.

Ideal for both DNA/RNA extraction

Built-in protocols are created for extracting nucleic acids from a wide range of samples, including whole blood, plasma (circulating free nucleic acid), tissue, bacteria, virus, plant and forensic.

Automatic Optical Measurements of OD Values

Built-in spectrophotometer and our optical module provide users the option to automatically measure OD values and concentration of final eluates upon completion of the nucleic acid extraction process.

UV Decontamination

The equipped UV lamp minimizes the risk of cross-contamination and ensures user and product safety.

HEPA Decontamination

HEPA system is installed in the PCR set up zone to eliminate contamination and ensure the purity of the samples.

Automatic Barcode Scanning

Barcode reading of primary tube simplifies the tracking of the samples and ensures traceability.

Throughput up to 48 samples

From cartridge piercing to final elute, all steps are performed by the instrument, that allows running 1–48 samples. The instrument processed samples in batches of 24 at a time and has run setting for 24/48 sample to be processed at once, for time saving and flexible performance.

Smart PCR setup

After pre-mix buffer configuration is set, the instrument automatically calculates the required volumes of the primers and perform liquid level detection. Pre-run report is generated to avoid errors and ensure optimal performance.



Automatic Optical Density Measurement

- Built-in spectrophotometer provides O.D. A_{260} and A_{280} measurement of individual samples. (O.D. detection range: ABS <6.)
- A_{260} Normalization
- Disposable cuvettes.

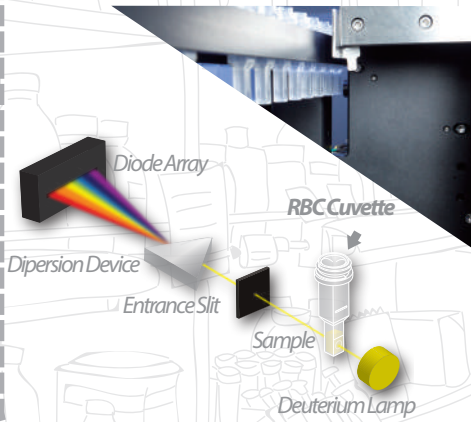

EDA System Connectivity

With LIMS compatibility EDA system can be connected to various thermocyclers and laboratory computer to set up automatic information exchange and analysis workflow.



Smart PCR Set Up

Zone B provides automatic PCR set up which is compatible with different thermocyclers for the further process. The system has 10 SBS positions, option of keeping premixes cool and the option of using 0.1 and 0.2 ml standard tubes, along from customised tubes from other PCR supplier.



Specification

Model	EDA
System Method	Cellulose coated magnetic beads
System Components	<ol style="list-style-type: none"> 1. Pipetting Unit: dispensing, transferring, 2 X-Y axis model 2. Electric Control: PLC model and Arm-based main board embedded in 3. UV Light: power 8W, life duration 11,000hrs 4. Contamination Prevention: HEPA filtration, Pipette tips with filter 5. Heating Block: RT-95°C 6. Nucleic Acid Concentration Detection Source: D2 lamp 7. Detection Wavelength: 230nm, 260nm, 280nm 8. Liquid detection sensor : PCR setup Zone 9. Barcode scanning: Primary tube 10. Accessories: T-rack, Cartridge racks, trash drawer, 96-well PCR plate rack, 32-well 1.5ml tube rack
Power Supply	Voltage: AC 200-240V; Frequency: 50/60Hz
Dimension	W1215*D900*H860 (mm)
Net Weight	240 Kg / 529 lbs

Operating Parameters

Processing Capacity	1-48 samples (in batches of 24)
Processing Time	30-120 minutes (depends on sample type)
Sample Volume	200/400/1200/4000 μ l (application dependent)
Elution Volume	30/40/60/100/150/200 μ l (application dependent)
Yield	200 μ l whole blood (average 6 μ g gDNA) 400 μ l whole blood (average 12 μ g gDNA)
Purity	DNA: O.D. A_{260}/A_{280} ratio 1.8 \pm 0.1 RNA: O.D. A_{260}/A_{280} ratio 2.0 \pm 0.2
Pipetting Accuracy	Extraction Zone: 40 μ l <5%; 60 μ l <2%; 100-900 μ l <1.5% PCR setup Zone: 5-20 μ l \leq 5%; 20-50 μ l \leq 1%

Operating Environment

Temperatures allowed during transportation, storage, and packaging	15°C-35°C
Temperatures allowed during operation	18°C-30°C
Pollution Degree	Level 2



MD 757096



RBC Bioscience Corp.
www.rbcbioscience.com
info@rbcbioscience.com

MagCore[®] Automated Nucleic Acid Extractor

The first instrument with
built-in Spectrophotometer

MagCore[®] Super



MagCore[®] Super is RBC Bioscience's most advanced and efficient automated workstation for nucleic acid extraction. It is the first platform to combine our Extractor and Spectrophotometer. Users can benefit from automated nucleic acid extraction and measurement of the OD value and concentration of the final eluate.



Automatic Optical Measurements of OD Values

Built-in spectrophotometer and our optical module provide users the option to automatically measure OD values and concentration of final eluates upon completion of the nucleic acid extraction process.

Test Report

Test results can be saved in the instrument, downloaded through the USB port and/or printed by the thermal printer.

USB Output (USB flash drive not provided)

USB Output allows users to conveniently save test reports in excel format and upload system updates with a USB flash drive.

Thermal Printer

Test reports are available in hard copy.

Laboratory Information Management System (LIMS)

Test results are automatically saved after optical measurements. You can save up to 1,600 tests in LIMS. Data can be easily transferred to a printer or computer in the same network and the report file can be subsequently processed by a LIMS.



Worldwide Patented Magnetic Beads

Cellulose-coated magnetic beads, coupled with our patented binding and separation technology, guarantee high quality extracts.



Ideal for both DNA/RNA Extraction

Built-in protocols are created for extracting nucleic acids from whole blood, plasma, tissue cell, plant cell, bacteria cell and virus samples.



UV Decontamination

The equipped UV lamp minimizes the risk of cross-contamination and ensures user and product safety.



High Capacity of 16 Samples

The instrument and protocols allow running up to 16 samples at one time, providing time-saving and flexible operation.



Built-in Programs (Upgradeable via USB ports, Plug&Play)

MagCore Super has built-in protocols for all of the extraction kits we offer. Simply run the protocol by selecting the 3-digit code printed on the kit of interest. MagCore[®] is equipped with a USB port. Free upgrade of software or protocols can be downloaded from our website (www.rbcbioscience.com).



Touch Screen with User-Friendly Interface

An integrated 7-inch full-color touch screen with user-friendly interface offers ease in operation. Only one touch is required to run your daily work.



Barcode Scanner

It enables sample tracking and monitoring throughout the entire purification process and helps organize test results.



Progress Monitoring

Remote (wireless) HMI device automatically transfers the data to your Android smartphone.

Easy To Use

Load Samples



Install Accessories

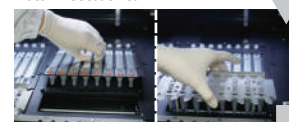

Select the code of the cartridge.

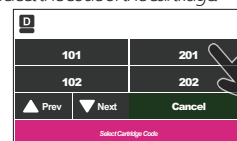

Select Sample Volume

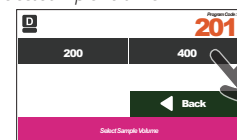

Press Start

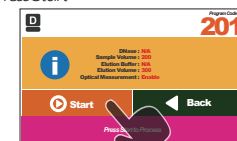

A Beep Sound can be heard after the program is complete!

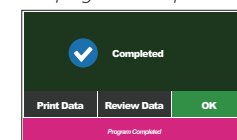

MagCore® Super System Overview

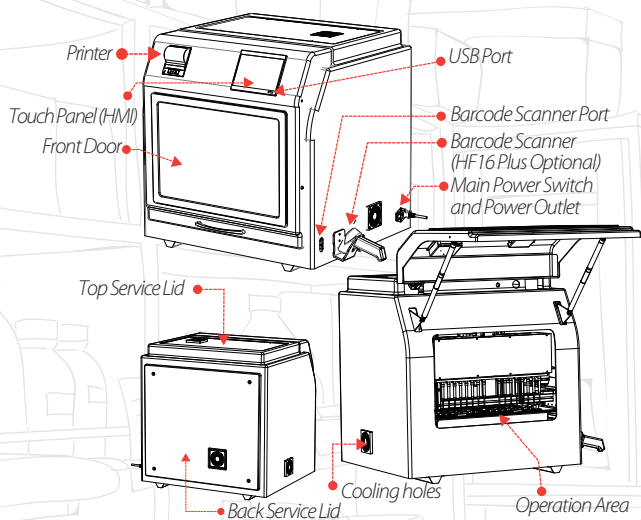

Cartridge Design and Extraction Principle

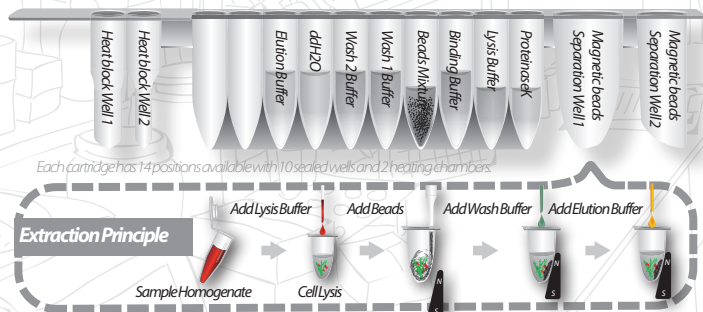

Specification

Model	Super
System Method	Cellulose coated magnetic beads
System Components	<ol style="list-style-type: none"> 1. Pipetting Unit: X and Y-axis movement for sample transfer and dispense. 2. Electric Control: PLC module and ARM-based main board embedded in 3. UV Light: power 8w, life duration 11,000hrs 4. Heating Block: RT-90°C 5. OD Detection Range: ABS 0-2.5 6. Detection Source: D2 lamp 7. Detection Wavelength: 260nm, 280nm 8. Display Screen: 7-inch color touch panel 9. Accessories: T-racks, cartridge racks, cuvette racks, barcode scanner, thermal printer
Power Supply	Voltage: AC 100V~240V; Frequency: 50/60Hz
Dimension	W760 x D700 x H770 (mm) / W29.92 x D27.55 x H30.31 (inches)
Net Weight	78kg / 171.99lbs

Operating Parameters

Processing Capacity	1-16 samples per batch
Processing Time	30-90 minutes (depends on sample type and method)
Sample Volume	200µl/400µl/1,200µl / 4ml * depending on the program.
Elution Volume	30µl/60µl/100µl/150µl/200µl
Yield	Average 6µg Genomic DNA from 200µl human whole blood
Purity	DNA: O.D. A ₂₆₀ /A ₂₈₀ ratio 1.8 ± 0.1 RNA: O.D. A ₂₆₀ /A ₂₈₀ ratio 2.0 ± 0.2
Pipetting Accuracy	500µl ≤ 4%

Automatic Optical Scanning and Retrieval of OD Values

- The optical module provides O.D. A₂₆₀ and A₂₈₀ measurement of individual samples. (O.D. detection range: ABS < 6.)
- A₃₂₀ Normalization
- Disposable cuvettes.

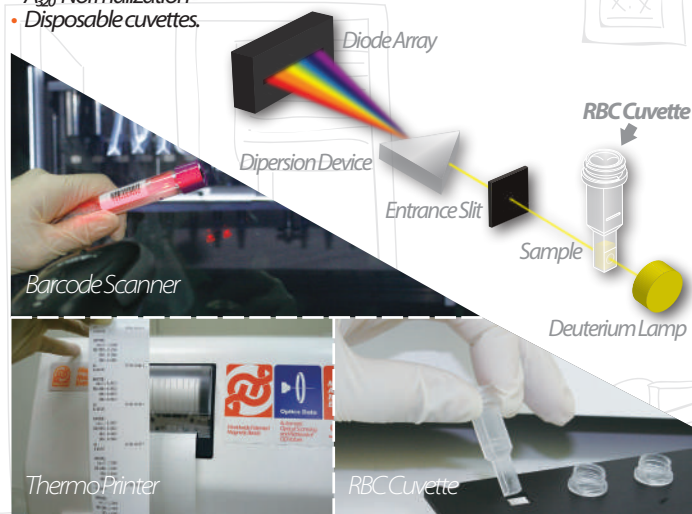

Laboratory Information Management System (LIMS)

Unidirectional LIMS device, Ethernet cable



Operating Environment

Temperatures allowed during transportation, storage, and packaging	15°C-35°C
Temperatures allowed during operation	18°C-30°C
Pollution Degree	Level 2



FDA (10055336) registered and CE-IVD certified (Instruments & Reagents)
Manufactured in accordance with quality system requirements that comply with ISO 13485 standards and QSR



MagCore® Nucleic Acid Extraction Kits



For selective DNA purification and size selection for NGS

MagCore® NGS-Clean up Kit is designed for fast DNA fragment cleanup and size selection. The cleanup program results in 80% or higher recovery while removing all adapter dimers in sample that is then applicable during the preparation of Next Generation Sequencing (NGS) library. For DNA fragment size selection, the program selectively purifies nucleic acid fragments from 100-200 bp or from 200-500 bp in just minutes which is also suitable for library preparation. The entire purification procedure is fully automated and can be performed in 35 minutes.

701

MagCore® NGS Clean-up Kit



Features

1. Automated DNA Cleanup and Size Selection ~30min
2. Precise Size Range Selection
3. High Recovery Rate
4. Easy and Rapid Workflow
5. Consistent and Reliable

Applications

The MagCore® NGS Clean up Kit is designed to purify DNA for various downstream applications, including:

1. DNA library preparation for NGS
2. PCR or real-time PCR



Performance

Product Introduction and Average Recovery

Program	Program Description	Average Recovery (%)
701A	DNA Cleanup	>80%
701B	DNA Size Selection 200-500bp	40-60%
701C	DNA Size Selection 100-200bp	>50%

Comparison of DNA Cleanup methods

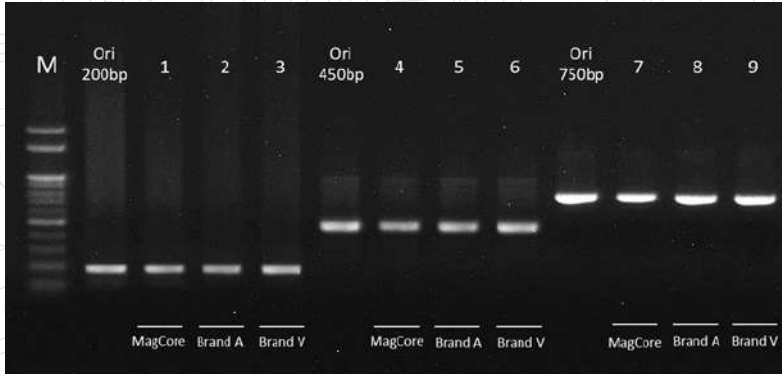

M: 100bp Marker.
 Lane 1, 4, 7: MagCore NGS-Clean up Kit cleanup DNA sample with 701A program.
 Lane 2, 5, 8: Brand A manually cleanup DNA sample.
 Lane 3, 6, 9: Brand V manually cleanup DNA sample.

MagCore NGS-Clean up Kit: results of the automatic cleanup of DNA sample are comparable with Brand A and Brand V manual kits, resulting in high purity product with >80% recovery.

Human genomic library prepared with DNA Library Prep Kit was analyzed by an Agilent Technologies 2100 Bioanalyzer

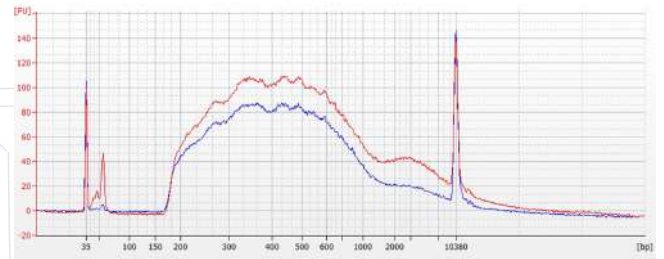

Red Line: Before DNA Clean-up
 Blue Line: After DNA Clean-up

Linear Increase in DNA yield

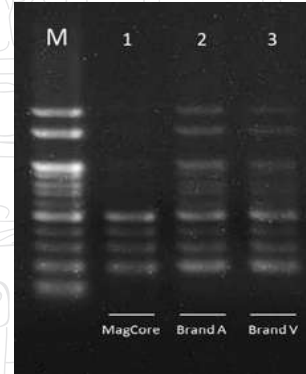

M: 100bp Marker.
 Lane 1: MagCore NGS-Clean up Kit size select 200-500bp with 701B program.
 Lane 2: Brand A manually size select 200-500bp.
 Lane 3: Brand V manually size select 200-500bp.

MagCore NGS-Clean up Kit is completely automated and can effectively size select DNA from 200-500bp, while Brand A and Brand V contain larger DNA fragments in the final product.

MagCore® Automated Nucleic Acid Kits Specification

Cartridge Code	MagCore® Super/HF16 Plus/Plus II			MagCore® HF16/Compact		
	Cat No.	Cat No.	Running Time	Cat No.	Cat No.	Running Time
701	36 preps	96 preps		36 preps	96 preps	
	MNC-01	MNC-02	35 min	MNC-01	MNC-02	35 min

701 MagCore® NGS Clean-up Kit
 For 50 µl sample volumes.
 Contents: Pre-Filled Cartridges, Disposable Tip & Holder Sets, Sample Tubes, Elution Tubes
 Shelf life: 18 months



MD 757696



RBC Bioscience Corp.
 www.rbcbioscience.com
 info@rbcbioscience.com

MagCore® Nucleic Acid Extraction Kits



For extraction of genomic DNA from human whole blood sample

MagCore® Genomic DNA Whole Blood Kit is designed for extraction of total DNA (including genomic, mitochondrial and viral DNA) from whole blood, plasma, serum and buffy coat. The pre-filled cartridge contains proteinase K, a chaotropic salt, and guanidine hydrochloride for cell lysis and protein degradation. They enhance the binding between cellulose-coated magnetic beads and DNA. High quality DNA is eluted by low salt elution buffer or water after the removal of contaminants. Purified DNA of approximately 20-30 kb is suitable for PCR or other downstream applications.

101

MagCore® Genomic DNA Whole Blood Kit (Speedy installation)



102

MagCore® Genomic DNA Whole Blood Kit



104

MagCore® Genomic DNA Large Volume Whole Blood Kit (1.2 ml)

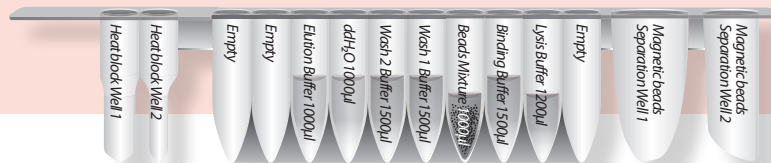

106

MagCore® Genomic DNA Whole Blood Kit (For Genotyping)



Features

1. High performance of purified DNA in downstream applications such as qPCR.
2. High analytical sensitivity
3. Cartridges are pre-filled and sealed to prevent contamination.
4. Walkaway processing improves work efficiency.

Applications

The MagCore® Genomic DNA Whole Blood Kit is designed to allow automated processing of multiple sample types in the same run. Sample types include:

1. Fresh and frozen whole blood
2. Buffy coat
3. Body fluids

High quality DNA available for various downstream applications, including:

1. PCR and real time PCR
2. Genotyping or sequencing
3. SNP, STR



Performance

DNA quality unaffected by anticoagulants

Anticoagulant	A _{260/280}	Conc.(ng/μl)
1. EDTA	1.87	99.3
2. Sodium Citrate	1.87	86.1
3. Lithium Heparin(4ml)	1.95	106.02
4. Sodium Fluoride	1.91	113.16
5. Lithium Heparin(9ml)	1.95	101.34

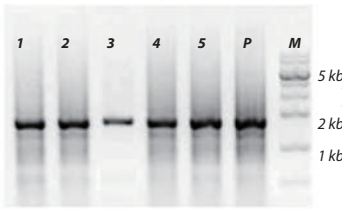

Consistent yield and purity

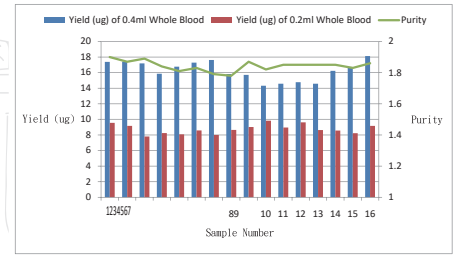

It is shown that there is a scalability of DNA isolation from blood samples (20, 50, 80, 100, 150, and 200 μl) by the MagCore® HF16. The amount of DNA was determined by A₂₆₀ measurement.

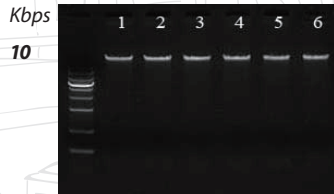

Linear Increase in DNA yield

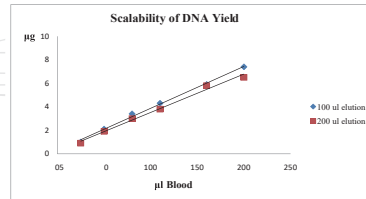

MagCore® Automated Nucleic Acid Kits Specification

MagCore® Super/HF16 Plus/Plus II

MagCore® HF16 / Compact / HF48

Cartridge Code	MagCore® Super/HF16 Plus/Plus II		MagCore® HF16 / Compact / HF48		
	Cat No.	Running Time	Cat No.	Running Time	Cat No.
	36 preps		36 preps		96 preps

101

MagCore® Genomic DNA Whole Blood Kit (Speedy installation)

For 200 and 400 μl sample volumes.
Contents: Pre-Filled Cartridges (Including Proteinase K), Disposable Tip & Holder Sets, Sample Tubes, Elution Tubes
Shelf life: 12 months

MGB400-01	MGB400-02	39 min (sample volume:200 μl) 50 min (sample volume:400 μl)	MGB400-01	MGB400-02	44 min (sample volume:200 μl) 57 min (sample volume:400 μl)
-----------	-----------	--	-----------	-----------	--

102

MagCore® Genomic DNA Whole Blood Kit

For 200 and 400 μl sample volumes.
Contents: Pre-Filled Cartridges (Including Proteinase K), Disposable Tip & Holder Sets, Sample Tubes, Elution Tubes
Shelf life: 18 months

MGB400-03	MGB400-04	39 min (sample volume:200 μl) 50 min (sample volume:400 μl)	MGB400-03	MGB400-04	44 min (sample volume:200 μl) 55 min (sample volume:400 μl)
-----------	-----------	--	-----------	-----------	--

104

MagCore® Genomic DNA Large Volume Whole Blood Kit (1.2 ml)

For 1200 μl sample volumes.
Contents: Pre-Filled Cartridges (Including Proteinase K), Disposable Tip & Holder Sets, Sample Tubes, Elution Tubes
Shelf life: 18 months

	MGB1200	76 min (sample volume:1200 μl)		MGB1200	83 min (sample volume:1200 μl)
--	---------	--------------------------------	--	---------	--------------------------------

106

MagCore® Genomic DNA Whole Blood Kit (For Genotyping)

For 200 and 400 μl sample volumes.
Contents: Pre-Filled Cartridges (Including Proteinase K), Disposable Tip & Holder Sets, Sample Tubes, Elution Tubes
Shelf life: 18 months

MGB400-07	MGB-400-08	41 min (sample volume:200 μl) 53 min (sample volume:400 μl) * optical detection is not provided	MGB400-07	MGB-400-08	44 min (sample volume:200 μl) 57 min (sample volume:400 μl) (Applicable models: HF16, Compact)
-----------	------------	---	-----------	------------	--

Enzyme Selection Guide

Product	Contents	Cat No.
Proteinase K Set	11 mg Proteinase K, 1.25 ml PK Storage Buffer	PK011
RNase A	50 μl RNase A (50mg/ml)	RN050
	130 μl RNase A (50mg/ml)	RN130



MD 757696



RBC Bioscience Corp.
www.rbcbioscience.com
info@rbcbioscience.com

MagCore® Nucleic Acid Extraction Kits



For extraction of free circulating DNA from human plasma or serum

MagCore® Plasma DNA Extraction Kit is designed for purifying free circulating DNA from human serum or plasma using MagCore® automated extraction systems. The kit contains all required reagents and labware for automated purification based on magnetic-particle technology. Reagents necessary for a complete process are supplied and pre-filled in the cartridges, which can be easily loaded into the MagCore® instrument.

105

MagCore® Plasma DNA Extraction Kit (1.2 ml)



Features

1. High performance of purified DNA in downstream applications such as qPCR.
2. Efficient recovery of fragmented DNA
3. Pre-filled and sealed buffer cartridges prevent contamination.
4. No phenol or chloroform extraction
5. Efficient removal of contaminants and inhibitors.

Applications

The MagCore® Plasma DNA Extraction Kit efficiently purifies free circulating DNA.

Sample types include:

1. Human plasma
2. Human serum

High quality DNA available for various downstream applications, including:

1. PCR and real-time PCR
2. Next Generation Sequencing (NGS)



Performance

High-quality of free DNA from plasma and serum

Quality and quantity analysis of the free DNA by Agilent Bioanalyzer 2100. Superior quality DNA are available from plasma and serum samples by using MagCore® products.

Sample ID	Sample type	Target Conc. (pg/μl)	35 bp marker Conc. (pg/μl)	10380 bp marker Conc. (pg/μl)
1	Human plasma	77.94	125	75
2	Human serum	138.48	125	75

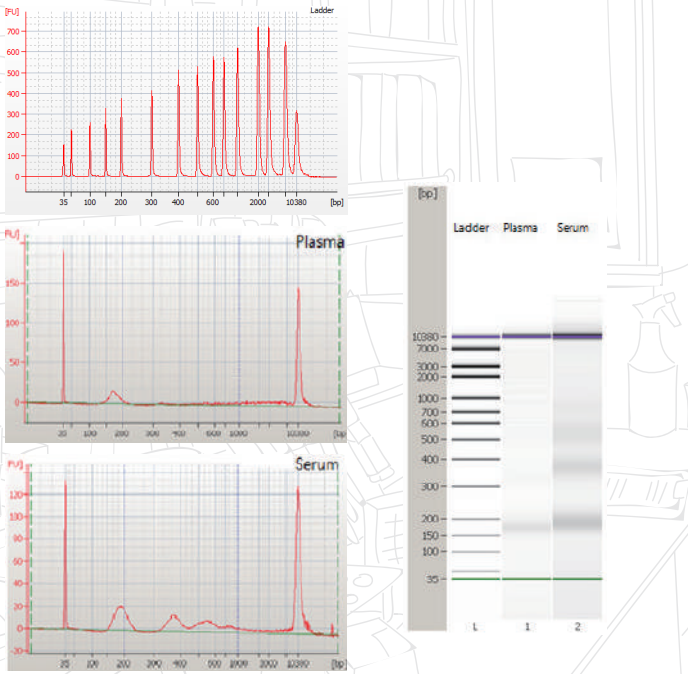

High stability of free DNA

Quality and quantity analysis of the free DNA by Agilent 2100 Bioanalyzer. It is shown by the evidence that free DNA of high quality and stability is possible to extract from 5 different plasma samples by using MagCore® products.

Sample ID	Sample type	Target Conc. (pg/μl)	35 bp marker conc. (pg/μl)	10380 bp marker Conc. (pg/μl)
1	Human plasma	65.95	125	75
2	Human plasma	76.63	125	75
3	Human plasma	87.22	125	75
4	Human plasma	57.96	125	75
5	Human plasma	60.53	125	75

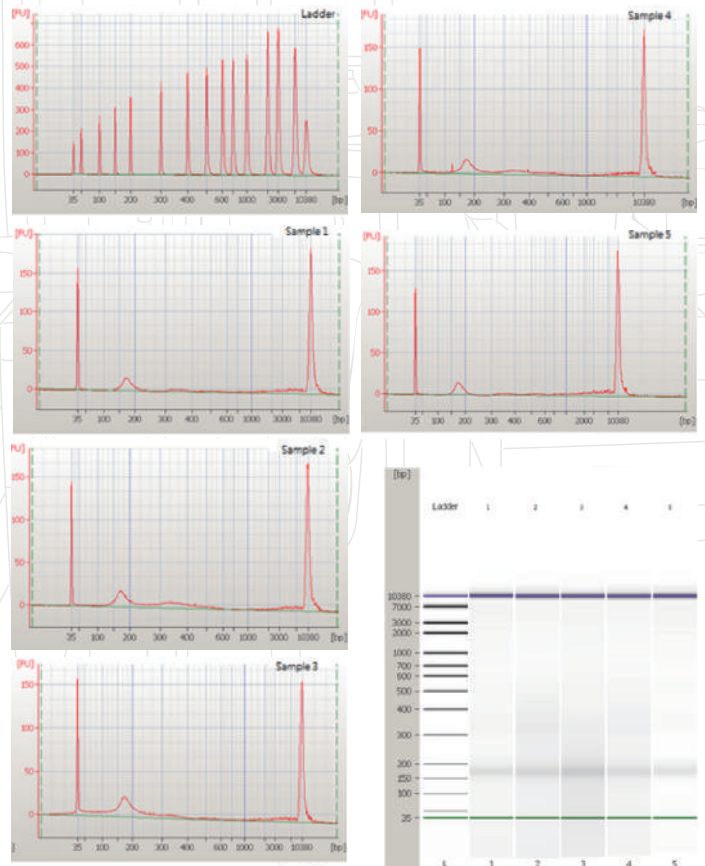

MagCore® Automated Nucleic Acid Kits Specification

MagCore® Super/HF16 Plus/Plus II				MagCore® HF16/Compact/HF48			
Cartridge Code	Cat No.	Running Time		Cat No.	Running Time		
	96preps			96preps			
105	MagCore® Plasma DNA Extraction Kit (1.2 ml) For 1200μl sample volumes. Contents: Pre-Filled Cartridges, Proteinase K, PK Storage Buffer, Disposable Tip & Holder Sets, Sample Tubes, Elution Tubes Shelf life: 18 months						
	MPD1200	74 min (sample volume: 1200μl) <small>*optical detection is not provided</small>		MPD1200	70 min (sample volume: 1200μl)		

Enzyme Selection Guide

Product	Contents	Cat. No.
Proteinase K Set	11 mg Proteinase K, 1.25 ml PK Storage Buffer	PK011
RNase A	50 μl RNase A (50mg/ml)	RN050
	130 μl RNase A (50mg/ml)	RN130



FDA (10055336) registered and CE-IVD certified (Instruments & Reagents)
Manufactured in accordance with quality system requirements that comply with ISO 13485 standards and QSR



MagCore® Nucleic Acid Extraction Kits



For genomic DNA extraction from cultured cells and amniotic fluid

MagCore® Cultured Cells DNA Kit is designed to extract genomic DNA from up to 5×10^6 cultured cells using MagCore® automated extraction systems. The kit contains all required reagents and labware for automated extraction using magnetic-particle technology. Reagents are supplied in pre-filled cartridges, which can be easily loaded into the MagCore® instrument.

110

MagCore® Cultured cells DNA Kit



Features

1. High performance of purified DNA in downstream applications such as qPCR.
2. Efficient isolation of DNA from up to 5×10^6 cells.
3. Cartridges are pre-filled and sealed to prevent contamination.
4. No phenol or chloroform extraction.
5. Efficient removal of contaminants and inhibitors.

Applications

High quality DNA available for various downstream applications, including:

1. PCR and real-time PCR
2. Next Generation Sequencing (NGS)



Performance

DNA quality analysis by Spectrophotometer

DNA of three different cultured cells were extracted by the employment of MagCore® HF16 and MagCore® Cultured Cells DNA Kit (200µl sample volume). The following data show the yield and purity of DNA of three samples.

Sample 1: COS7 (1.2x10⁷)
 Sample 2: Junkat (1x10⁹)
 Sample 3: HEK293 (1x10⁹)

	1	2	3
Yield (mg)	16.44	13.08	24.42
DNA purity (A _{260/280})	1.93	1.87	1.92

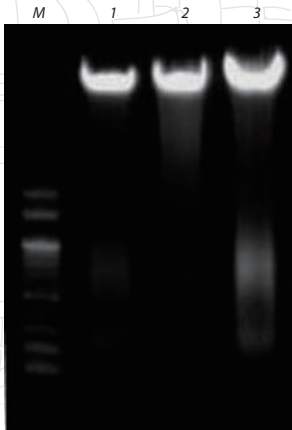

Amniotic fluid DNA extraction

Result

DNA quality is checked by the NanoDrop spectrophotometer and agarose gel electrophoresis after DNA purification from amniotic fluid cells. Cells were harvested from 10~15 ml amniotic fluid samples at pregnancy weeks 16-18 by centrifugation for 10 minutes at 3000rpm.

Sample ID	Conc. (pg/µl)	A _{260/280}	A _{260/230}	Yield (µg)
(1) GPT2967P	22.68	1.84	1.07	1.36
(2) GPT2952P	33.98	1.92	1.57	2.04
(3) NP679P	33.65	1.80	1.34	2.02
(4) NP777P	39.22	1.86	1.20	2.35
(5) MP795P	22.05	1.79	0.97	1.32

by NanoDrop ND-1000

Table 1. DNA quality analysis by NanoDrop.

Sample ID (1) to (5) are different amniotic fluid samples. It is shown that MagCore® HF16 system can purify 1~2 µg DNA from 10~15 ml amniotic fluid samples and DNA purity is with the A_{260/280} ratio of around 1.8±0.1

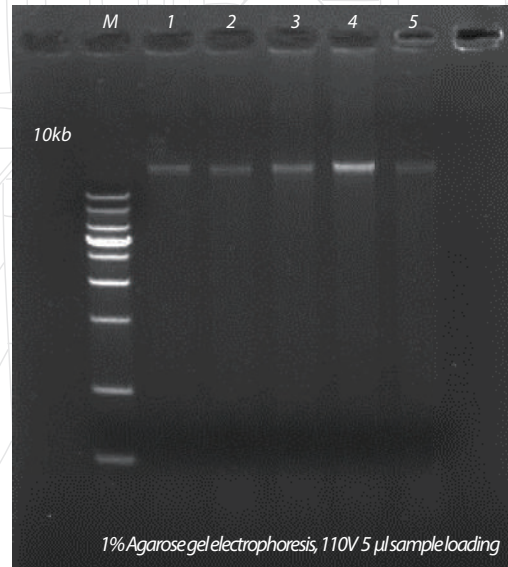

Figure 1. Genomic DNA isolations were run by gel electrophoresis on 1% agarose gel. Lane M: RBC 1kb ladder marker
 Lane 1: GPT2967P
 Lane 2: GPT2952P
 Lane 3: NP679P
 Lane 4: NP777P
 Lane 5: NP795P

MagCore® Automated Nucleic Acid Kits Specification

Cartridge Code	MagCore® Super/HF16 Plus/Plus II			MagCore® HF16 /Compact/HF48		
	Cat No.	Cat No.	Running Time	Cat No.	Cat No.	Running Time
	36 preps	96 preps		36 preps	96 preps	

110

MagCore® Cultured Cells DNA Kit

For 200µl sample volumes (up to 5x10⁶ cells)

Contents: Pre-Filled Cartridges, Proteinase K, PK Storage Buffer, Disposable Tip & Holder Sets, Sample Tubes, Elution Tubes
 Shelf life: 18 months

MCC-01SP	MCC-02SP	39 min (sample volume: 200µl, up to 5x10 ⁶ cells) *optical detection is not provided	MCC-01	MCC-02	44 min (sample volume: 200µl, up to 5x10 ⁶ cells)
----------	----------	--	--------	--------	--

Enzyme Selection Guide

Product	Contents	Cat No.
Proteinase K Set	11 mg Proteinase K, 1.25 ml PK Storage Buffer	PK011
RNase A	50 µl RNase A (50mg/ml)	RN050
	130 µl RNase A (50mg/ml)	RN130



FDA (10055336) registered and CE-IVD certified (Instruments & Reagents)
 Manufactured in accordance with quality system requirements that comply with ISO 13485 standards and QSR



MagCore® Nucleic Acid Extraction Kits



For extraction of cfDNA from 4ml plasma or serum

MagCore® Circulating DNA large volume kit is designed for purifying free circulating DNA from human serum or plasma using MagCore® automated extraction systems. The kit contains all required reagents and labware for automated purification based on magnetic-particle technology. Reagents necessary for a complete process are supplied and pre-filled in the cartridges, which can be easily loaded into the MagCore® instrument.

115

MagCore® Circulating DNA large volume kit (4ml)

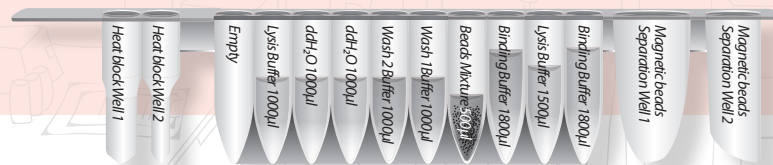

Features

1. High performance of purified DNA in downstream applications such as qPCR.
2. Efficient recovery of fragmented DNA
3. Pre-filled and sealed buffer cartridges prevent contamination.
4. No phenol or chloroform extraction
5. Efficient removal of contaminants and inhibitors.

Applications

The MagCore® Plasma DNA Extraction Kit efficiently purifies free circulating DNA.

Sample types include:

1. Human plasma
2. Human serum

High quality DNA available for various downstream applications, including:

1. PCR and real-time PCR
2. Next Generation Sequencing (NGS)



Performance

High stability of free DNA

Quality and quantity analysis of the free DNA by Agilent 2100 Bioanalyzer. It is shown by the evidence that free DNA of high quality and stability is possible to extract from 5 different healthy people plasma samples by using MagCore products.

Sample ID	Sample type	Plasma (ml)	Qubit (ng/ul)	Ct value (GAPDH gene)	Bioanalyzer Conc. (pg/ul)	35 bp marker Conc. (pg/ul)	10380 bp marker Conc. (pg/ul)
1	Human plasma	4	0.262	18.52	127.21	125	75
2	Human plasma	4	0.250	18.59	124.62	125	75
3	Human plasma	4	0.220	18.78	111.11	125	75
4	Human plasma	4	0.290	18.45	153.24	125	75
5	Human plasma	4	0.278	18.49	130.97	125	75

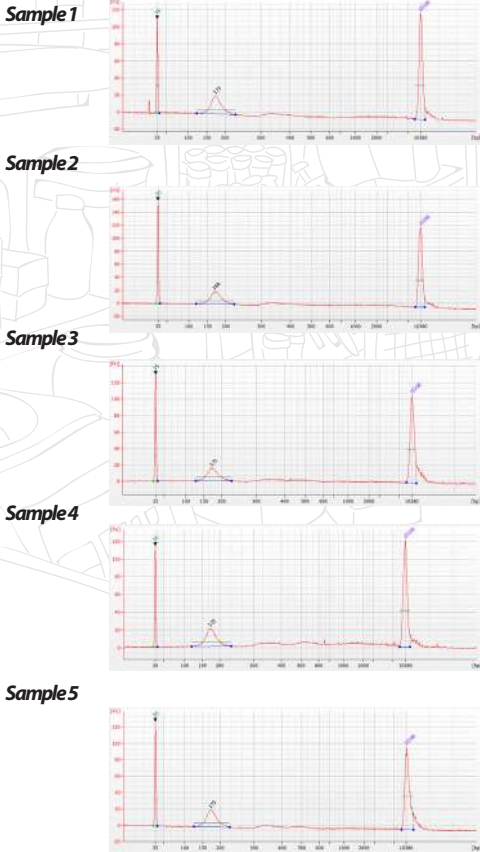

Comparison of free DNA from 1.2 ml and 4 ml plasma

Quality and quantity analysis of the free DNA by Agilent Bioanalyzer 2100. Superior quality DNA are available from plasma samples by using MagCore products.

Sample ID	Kits Code	Sample type	Plasma (ml)	Qubit (ng/ul)	Ct value (GAPDH gene)	Bioanalyzer Conc. (pg/ul)	35 bp marker Conc. (pg/ul)	10380 bp marker Conc. (pg/ul)
1	105	Human plasma	1.2	0.061	23.86	24.70	125	75
2	105	Human plasma	1.2	0.058	23.96	22.98	125	75
3	115	Human plasma	4	0.203	20.04	117.0	125	75
4	115	Human plasma	4	0.194	20.26	104.7	125	75

Code 105: MagCore® Plasma DNA Extraction Kit
Code 115: MagCore® Circulating DNA large volume kit

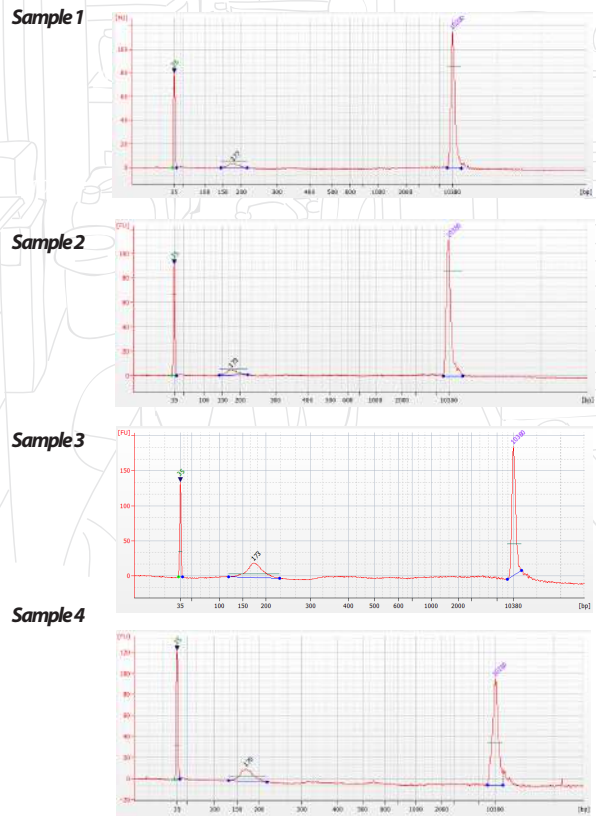

MagCore® Automated Nucleic Acid Kits Specification

Cartridge Code	MagCore® Super/HF16 Plus/Plus II			MagCore® HF16/Compact		
	Cat No.	Cat No.	Running Time	Cat No.	Cat No.	Running Time
115	24 preps	96 preps		24 preps	96 preps	
	MPD4000-01	MPD4000-03	146 min (sample volume: 4000 µl) *optical detection is not provided	MPD4000-01	MPD4000-03	146 min (sample volume: 4000 µl)

Enzyme Selection Guide

Product	Contents	Cat No.
Proteinase K Set	11 mg Proteinase K, 1.25 ml PK Storage Buffer	PK011
RNase A	50 µl RNase A (50 mg/ml)	RN050
	130 µl RNase A (50 mg/ml)	RN130



FDA (10055336) registered and CE-IVD certified (Instruments & Reagents)
Manufactured in accordance with quality system requirements that comply with ISO 13485 standards and QSR



MagCore® Nucleic Acid Extraction Kits



For extraction of viral DNA/RNA from serum, plasma and cell-free body fluids

The MagCore® Viral Nucleic Acid Extraction Kit is designed for purifying viral DNA and RNA from serum, plasma, and cell free body fluids. MagCore® magnetic particle technology delivers high-quality DNA/RNA that is suitable for direct use in downstream applications such as amplification or other enzymatic reactions. To minimize the risk of cross-contamination, plastic consumables inside the Kit are DNase/RNase treated and the operation system is designed to individually process samples at the same time. Multiple protocols are installed on the instrument and optimized for different sample volumes.

202

MagCore® Viral Nucleic Acid Extraction Kit (Low PCR Inhibition)



210

MagCore® Viral Nucleic Acid Large Volume Extraction Kit (2.4 ml)

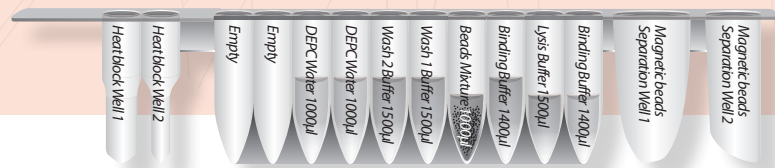

211

MagCore® Viral Nucleic Acid Large Volume Extraction Kit (1.2 ml)

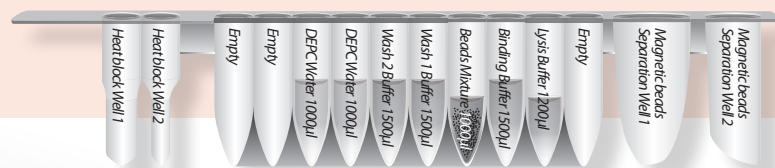

Features

1. High performance of purified DNA in downstream applications such as qPCR.
2. High analytical sensitivity.
3. Cartridges are pre-filled and sealed to prevent contamination.
4. Walkaway processing improves work efficiency.

Applications

MagCore® Viral Nucleic Acid Extraction Kit is designed to allow automated processing of multiple sample types in the same run. Sample types include:

1. Cell-free body fluids
2. Plasma and serum
3. CSF
4. Urine



Performance

HBV detection by Real-Time PCR

The isolations of HBV nucleic acid from samples containing different concentrations of HBV were subsequently detected by Real-Time PCR

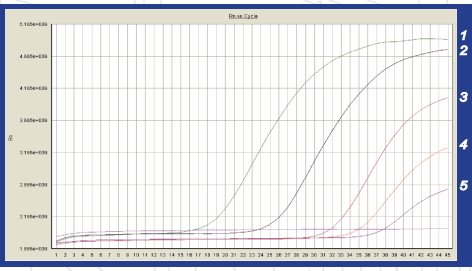

Sensitivity test for HBV detection

Lane 1	1x10 ⁸ HBV serums.
Lane 2	1x10 ⁷ HBV serums.
Lane 3	1x10 ⁶ HBV serums.
Lane 4	1x10 ⁵ HBV serums.
Lane N	Negative control.
Lane M	RBC 100 bp DNA Ladder Marker.

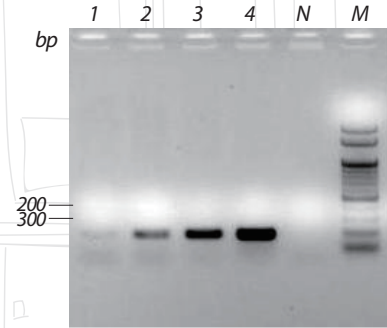

Figure 1. Nested PCR results of HBV at different concentrations. Viral nucleic acids were purified from samples containing different amount of HBV using MagCore[®] Viral Nucleic Acid Extraction Kit.

Sensitivity test for HCV detection

Lane 1	5x10 ⁸ HCV serums.
Lane 2	5x10 ⁷ HCV serums.
Lane 3	5x10 ⁶ HCV serums.
Lane 4	5x10 ⁵ HCV serums.
Lane 5	5x10 ⁴ HCV serums.
Lane 6	5x10 ³ HCV serums.
Lane P	Positive control.
Lane N	Negative control.
Lane M	RBC 100 bp DNA Ladder Marker.

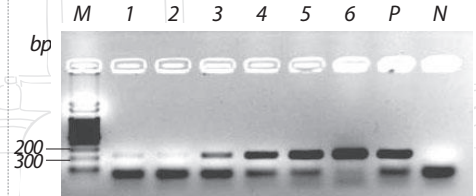

Figure 2. Nested PCR results of HCV at different concentrations. Viral nucleic acids were purified from samples containing different amount of HCV using MagCore[®] Viral Nucleic Acid Extraction Kit.

MagCore[®] Automated Nucleic Acid Kits Specification

Cartridge Code	MagCore [®] Super/HF16 Plus/Plus II			MagCore [®] HF16 / Compact/HF48		
	Cat No.	Cat No.	Running Time	Cat No.	Cat No.	Running Time
	36 preps	96 preps		36 preps	96 preps	
202	MagCore[®] Viral Nucleic Acid Extraction Kit (Low PCR Inhibition)					
	For 200 and 400 µl sample volumes. Contents: Pre-Filled Cartridges, Proteinase K, PK Storage Buffer, Carrier RNA, Rnase Free Water, Disposable Tip & Holder Sets, Sample Tubes, Elution Tubes Shelf life: 18 months					
	MVN400-03	MVN400-04	62 min (sample volume:200 µl) 73 min (sample volume:400 µl) *optical detection is not provided	MVN400-03	MVN400-04	57 min (sample volume:200 µl) 66 min (sample volume:400 µl)
210	MagCore[®] Viral Nucleic Acid Large Volume Extraction Kit (2.4 ml)					
	For 2400 µl sample volumes. Contents: Pre-Filled Cartridges, Proteinase K, PK Storage Buffer, Carrier RNA, Rnase Free Water, Disposable Tip & Holder Sets, Sample Tubes, Elution Tubes (special T-rack required for 5 ml sample tubes) Shelf life: 18 months					
					MVN2400	90 min (sample volume:2400 µl) (Applicable models:HF16, Compact)
211	MagCore[®] Viral Nucleic Acid Large Volume Extraction Kit (1.2 ml)					
	For 1200 µl sample volumes. Contents: Pre-Filled Cartridges, Proteinase K, PK Storage Buffer, Carrier RNA, Rnase Free Water, Disposable Tip & Holder Sets, Sample Tubes, Elution Tubes Shelf life: 18 months					
		MVN1200	80 min (sample volume:1200 µl) *optical detection is not provided		MVN1200	73 min (sample volume:1200 µl)

Enzyme Selection Guide

Product	Contents	Cat No.
Proteinase K Set	11 mg Proteinase K, 1.25 ml PK Storage Buffer	PK011
Carrier RNA Set	1mg Carrier RNA, RNase Free Water	CR001



FDA (10055336) registered and CE-IVD certified (Instruments & Reagents)
Manufactured in accordance with quality system requirements that comply with ISO 13485 standards and QSR



MagCore® Nucleic Acid Extraction Kits



For Extraction of Viral DNA/RNA From Serum, Plasma, Swabs and Cell-Free Body Fluids by Using MagCore® System

MagCore® Viral Nucleic Acid Kits are designed to isolate viral DNA and/or RNA from plasma, serum, swabs and cell-free body fluids. All plastic consumables included in the kits are DNase/RNase-free to minimize the risk of cross contamination. Our patented magnetic beads will bind to the short DNA fragments with high affinity ensuring that all important genetic information is collected efficiently making your daily isolation routine easier and faster. This kit also features Internal Control selection in its protocol, being compatible with any viral detection kit.

203

MagCore® Viral Nucleic Acid Extraction Kit (High Sensitivity)



Features

1. Higher analytical sensitivity.
2. Consistent and reproducible results.
3. High performance of purified DNA/RNA in downstream applications such as qPCR.
4. Cartridges are pre-filled and sealed to prevent contamination.
5. Provides the option of Internal Control selection.

Applications

MagCore® Viral Nucleic Acid Extraction Kit allows automated processing of multiple sample types in the same run, including:

1. Cell-Free Body Fluids
2. Plasma and Serum
3. CSF
4. Urine
5. Swabs



Performance

Viral Nucleic Acid Extraction Performance Analysis

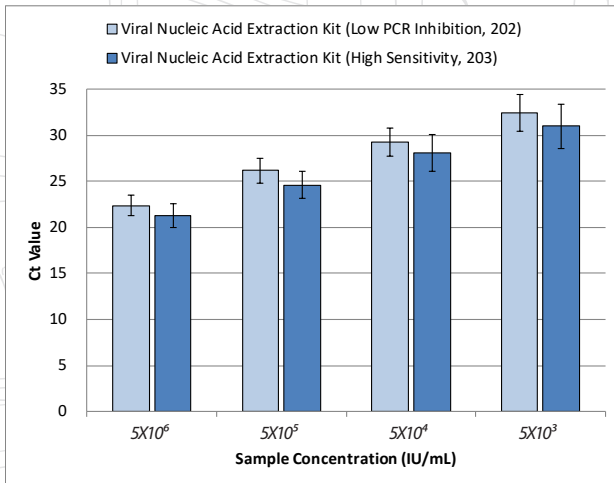

MagCore®203 shows better performance on real-time PCR with approximately 1~2Ct Value less. (n≥3)

Comparison of real-time PCR results of nucleic acid extraction by MagCore®, Brand Q and Brand R

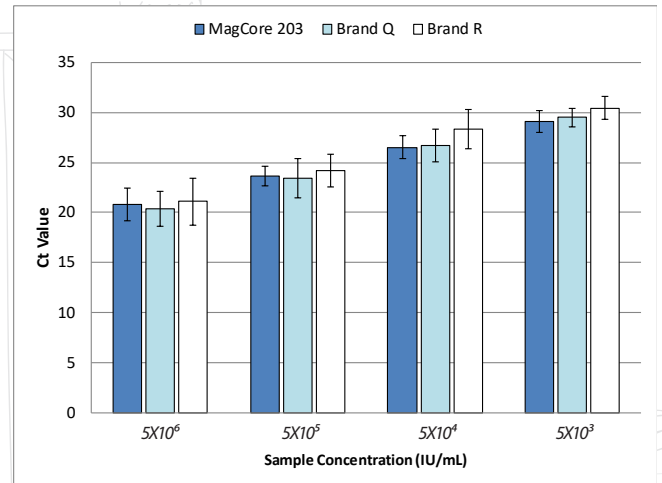

Purified viral nucleic acid by MagCore® is ideal for the downstream real-time PCR. Viral samples processed by MagCore®

Internal Control (IC) Selection

No.	Kit	Signal	Sample Concentration (IU/mL) – HBV Signal / IC Signal				NTC
			5x10 ⁶	5x10 ⁵	5x10 ⁴	5x10 ³	
1	MagCore® 203	HBV	22.06	25.39	28.58	30.53	-/-
		+IC	29.99	31.54	31.17	31.55	
2		HBV	23.82	26.51	29.78	33.17	
		+IC	31.19	30.79	30.51	32.73	

MagCore®203 program provides internal control (IC) selection, and the real-time PCR analyzed by CE IVD HBV Quantification kit shows IC signal within criteria (Ct value 30±3). This confirms success in MagCore®203 viral extraction step and low co-purification of PCR inhibitors that may cause false amplification patterns.

MagCore® Automated Nucleic Acid Kits Specification

Cartridge Code	MagCore® Super / HF16 Plus / Plus II			MagCore® HF16 / Compact / HF48		
	Cat No.	Cat No.	Running Time	Cat No.	Cat No.	Running Time
	36 preps	96 preps		36 preps	96 preps	

203 MagCore® Viral Nucleic Acid Extraction Kit (High Sensitivity)

For 200 and 400 µl sample volumes.
 Contents: Pre-filled Cartridges, Proteinase K, PK Storage Buffer, Carrier RNA, RNase Free Water, Disposable Tip & Holder Sets, Sample Tubes, Elution Tubes.
 Shelf life: 12 months

MVN400-05	MVN400-06	57 Mins / With IC Selection: 58 Mins (sample volume: 200 µl) 66 Mins / With IC Selection: 67 Mins (sample volume: 400 µl)	MVN400-05	MVN400-06	56 Mins / With IC Selection: 57 Mins (sample volume: 200 µl) 72 Mins / With IC Selection: 73 Mins (sample volume: 400 µl)
-----------	-----------	--	-----------	-----------	--

Enzyme Selection Guide

Product	Contents	Cat. No.
Proteinase K Set	11 mg Proteinase K, 1.25 ml PK Storage Buffer	PK011
Carrier RNA Set	1 mg Carrier RNA, RNase Free Water	CR001



FDA (10055336) registered and CE-IVD certified (Instruments & Reagents)
 Manufactured in accordance with quality system requirements that comply with ISO 13485 standards and QSR



MagCore® Nucleic Acid Extraction Kits



For extraction of plant DNA from plant tissues

MagCore® Genomic DNA Plant Kit is designed to extract DNA from plant tissues and cells using MagCore® automated extraction systems. The provided Filter Column Set can filtrate hard tissue samples to prevent tissue residues from clogging the pipette syringe. The kit contains all required reagents and labware for automated extraction using magnetic-particle technology. Reagents are supplied and pre-filled in cartridges, which can be easily loaded into the MagCore® instrument.

301

MagCore® Genomic DNA Plant Kit



Features

1. Lysis buffer can degrade large amounts of polysaccharides present on plant cell walls
2. Cartridges are pre-filled and sealed to prevent contamination.
3. No phenol or chloroform extraction and alcohol precipitation.
4. Efficient removal of contaminants and inhibitors.

Applications

The MagCore® Genomic DNA Plant Kit enables DNA purification from various samples types, including:

1. Plant cells
2. Plant tissues

High quality DNA available for downstream applications, including:

1. PCR and real-time PCR
2. Next Generation Sequencing (NGS)



Performance

Yields of nucleic acid purified from various sources by MagCore® Genomic DNA Plant Kit

Sample ID	Position	Yield (ng/μl)
Citrus nobilis Lour.	Leaf	36.5
Carica papaya	Leaf	49.2
Lycopersicon esculentum	Leaf	71.9
Citrullus lanatus	Leaf	23.4
Anisogonium esculentum	Leaf	240.3
Trachycarpus fortunei	Leaf	154.7
Mentha piperita	Leaf	54.6
Anthoceros punctatus	Leaf	38.9
Calix babylonica	Leaf	80.7
Prunus campanulata	Leaf	35.7
Lxeris chinensis	Leaf	161.4
Capsicum annum	Leaf	13.9
Vigna radiata	Seed	7.0
Medicago sativa	Leaf	21.0
Vigna angularis	Seed	5.8
Agaricus bisporus	Whole	14.3

MagCore® Automated Nucleic Acid Kits Specification

Cartridge Code	MagCore® Super/HF16 Plus/Plus II			MagCore® HF16/Compact/HF48		
	Cat.No.	Cat.No.	Running Time	Cat.No.	Cat.No.	Running Time
301	36 preps	96 preps		36 preps	96 preps	

301

MagCore® Genomic DNA Plant Kit

For 50-100 mg fresh tissues or 5-20 mg dried plant tissues

Contents: Pre-Filled Cartridges, RNase A, GP1 Buffer, GP2 Buffer, Filter Column Sets, Disposable Tip & Holder Sets, Sample Tubes, Elution Tubes

Shelf life: 18 months

MGP-01	MGP-02	Time: 33 min (sample volume: 400 μl) *optical detection is not provided	MGP-01	MGP-02	33 min (sample volume: 400 μl) (Applicable models: HF16, Compact)
--------	--------	--	--------	--------	--

Enzyme Selection Guide

Product	Contents	Cat. No.
Proteinase K Set	11 mg Proteinase K, 1.25 ml PK Storage Buffer	PK011
RNase A	50 μl RNase A (50 mg/ml)	RN050
	130 μl RNase A (50 mg/ml)	RN130



MD 757696



RBC Bioscience Corp.

www.rbcbioscience.com
info@rbcbioscience.com

FDA (10055336) registered and CE-IVD certified (Instruments & Reagents)

Manufactured in accordance with quality system requirements that comply with ISO 13485 standards and QSR

20110425

MagCore® Nucleic Acid Extraction Kits



For extraction of genomic DNA from tissues, swabs, FFPE, stool, feed/soil and forensic samples

MagCore® Genomic DNA Tissue Kit is designed for purification of total DNA (including genomic, mitochondrial and viral DNA) from a variety of animal tissues or cells by using MagCore® auto-extraction instrument. The provided Filter Column can filtrate hard tissue sample or swab sample to prevent tissue residues to obstruct pipette tip during the process of MagCore®. The method uses pre-filled cartridges based on cellulose coated magnetic bead technology.

401

401 MagCore® Genomic DNA Tissue Kit

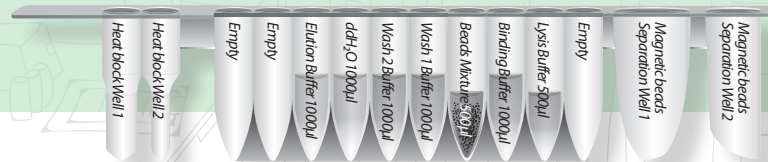

Features

1. Suitable for a wide variety of sample types, including forensic samples
2. Consistent and reproducible results
3. Purified DNA of approximately 20-30 kb in length is suitable for PCR or other enzymatic reactions.

Applications

MagCore® Genomic DNA Tissue kit allows processing multiple sample types in the same run, including:

1. Animal Tissues: Solid animal tissue, Stool samples
2. Swabs
3. Feed and soil samples
4. Formalin-fixed, Paraffin-embedded (FFPE) tissues samples (manual pretreatment)
5. Cultured Yeast samples
6. Forensics samples



Performance

DNA yield gained from 10mg of mice tissue samples and 0.25 cm tail

Mice tissue	Yield (ng/ul)
Liver	17.5
Spleen	17.5
Brain	10
Lung	12.5
Kidney	32.5
Tail	7.5

Table 1. Genomic DNA was purified from 10mg of mice tissue samples and 0.25cm tail.

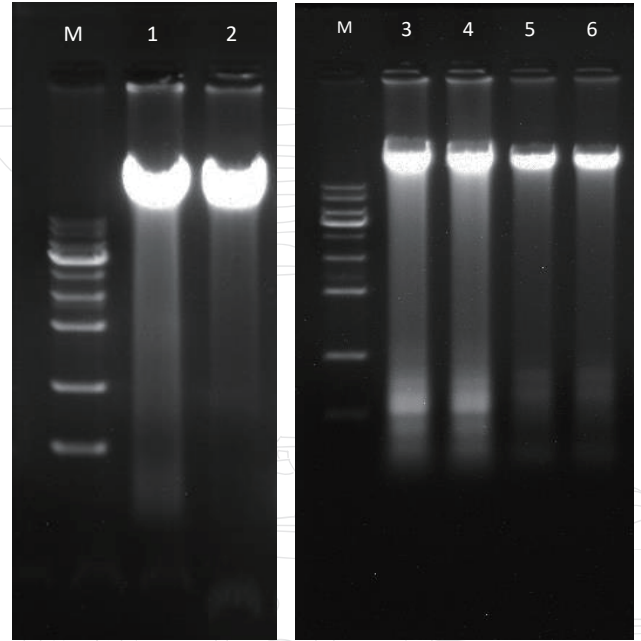

Figure 2. Agarose gel electrophoresis of the various animal tissue DNA was isolated from MagCore® automated extraction. ; Lane M: RBC 1 kb DNA ladder Marker; Lane 1: Rat kidney; Lane 2: Rat liver; Lane 3-4: Pork liver; Lane 5-6: Fish tissue.

Yield and quality of gDNA purified using MagCore® 401 Extraction Kit

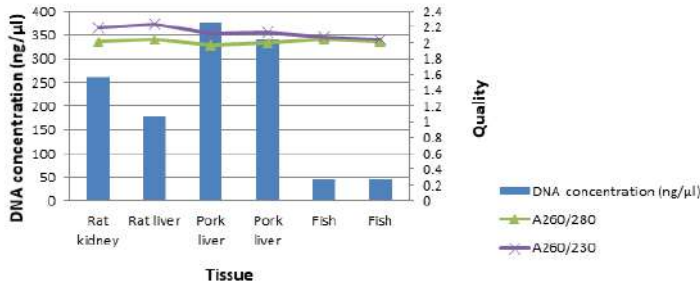

Figure 1. Genomic DNA from 10mg of various animal tissues were extracted by the MagCore®401 Genomic DNA Tissue Kit. DNA was eluted in 60µL and quantitated using Nanodrop n-1000.

MagCore® Automated Nucleic Acid Kits Specification

Cartridge Code	MagCore® Super/HF16 Plus/Plus II			MagCore® HF16 /Compact/HF48		
	Cat No.	Cat No.	Running Time	Cat No.	Cat No.	Running Time
401	36 preps	96 preps		36 preps	96 preps	
	MGT-01	MGT-02	33 min (sample volume:400 µl) *optical detection is not provided	MGT-01	MGT-02	33 min (sample volume:400 µl)

Enzyme Selection Guide

Product	Contents	Cat. No.
Proteinase K Set	11 mg Proteinase K, 1.25 ml PK Storage Buffer	PK011
RNase A	50 µl RNase A (50mg/ml)	RN050
	130 µl RNase A (50mg/ml)	RN130



FDA (10055336) registered and CE-IVD certified (Instruments & Reagents)
Manufactured in accordance with quality system requirements that comply with ISO 13485 standards and QSR



MagCore® Nucleic Acid Extraction Kits



For Automated Extraction of Genomic DNA from Formalin-fixed Paraffin-embedded (FFPE) Tissue

MagCore® Genomic DNA FFPE One-Step Kit is designed to purify total DNA (including genomic, mitochondrial, and viral DNA) from Formalin-fixed Paraffin-embedded tissues via MagCore® Automated Extraction instruments. Our program features One-Step Heating, which automatically melts paraffin and lyses cells at the same time. No harmful reagent such as xylene is involved in the deparaffination process. Two protocols are outlined for different tissues sizes: 2-hour setup for smaller tissues and 16-hour setup for larger tissues.

405

405 MagCore® Genomic DNA FFPE One-Step Kit



Features

1. Can load FFPE tissue samples with a surface area of up to 300 mm² and up to 5 µm thick.
2. A full package for DNA to be purified from FFPE samples. Complete automatic procedure from deparaffination to elution.
3. Stable deparaffination by Sula oil and reproducible results; no xylene involved.
4. The most stable cap is specially designed to cover the reaction well for an optimal condition where the lysis buffer and the FFPE sample can mix properly during the processing period.

Applications

1. PCR and real-time quantitative PCR
2. Southern Blot
3. Next Generation Sequencing
4. Genotyping

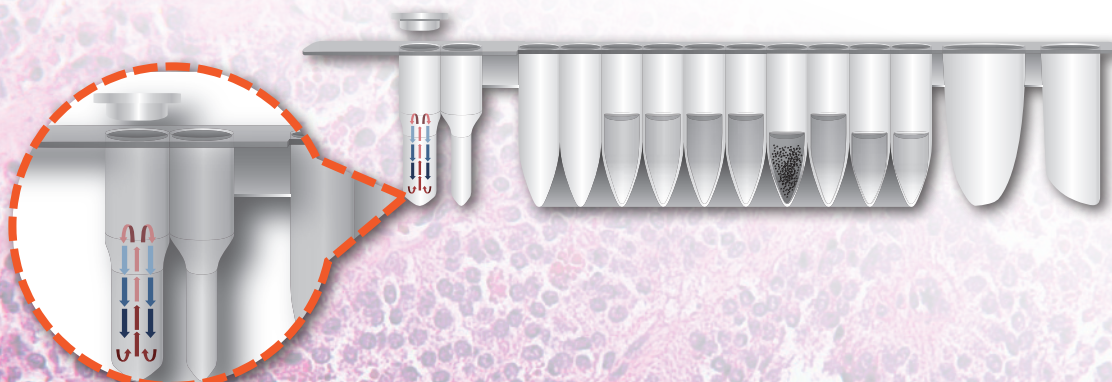

Performance

2-hr heating protocol works out

There are 2-hour heating and 16-hour heating protocols. It is suggested for a better performance that the 2-hour heating program is for small tissues and the 16-hour program is for large tissues.

Genomic DNA with high performance

The DNA extracted by MagCore® Genomic DNA FFPE One-Step Kit is high yield and suitable for downstream PCR and real-time PCR.

A. DNA concentration

Whether samples were treated with either a 2-hour or 16-hour heating, yields of DNA extracted by MagCore® are mostly higher than the yields of DNA extracted by the competitor.

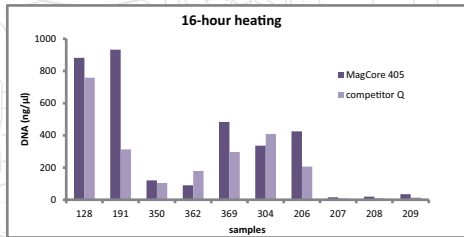
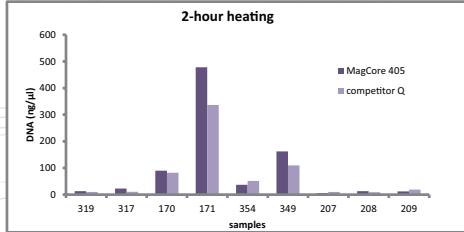

B. The downstream PCR

PCR products of DNA purified by MagCore® and the competitor brand are confirmed by 1.5% agarose gel electrophoresis.

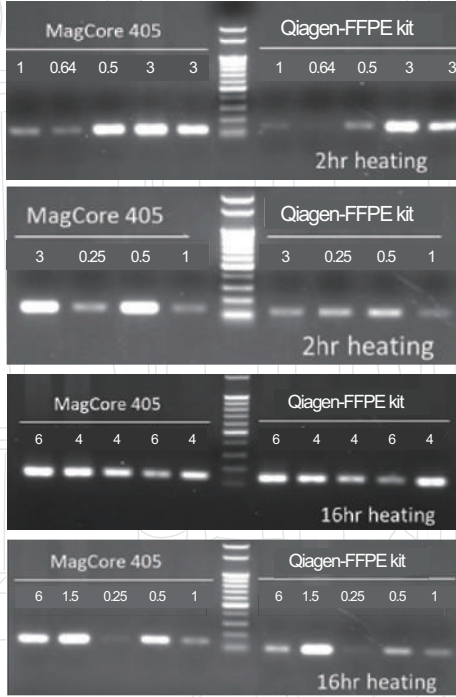

DNA yield gained from 10 mg of mice tissue samples and 0.25 cm tail

Sample ID	Yield (ng/ul)
Liver	17.5
Spleen	17.5
Brain	10
Lung	12.5
Kidney	32.5
Tail	7.5

C. Purified DNA ideal for the downstream real-time PCR

Whether samples experience a 2-hour or 16-hour heating, the CT values of samples processed by MagCore® are mostly lower than the CT values of samples processed by the competitor.

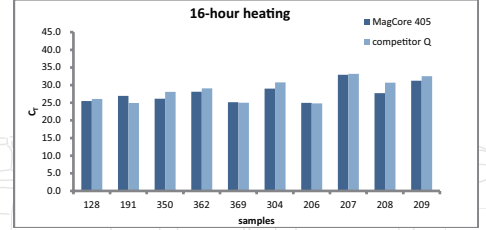
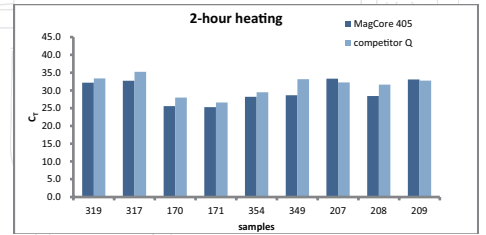

D. Tissue sample sizes

It is shown below that different sizes of tissue samples were processed by a 2-hour or 16-hour heating program.

2-hour heating			16-hour heating		
Sample	Size (cm ²)		Sample	Size (cm ²)	
1	319	1*1	1	128	2*3
2	317	0.8*0.8	2	191	2*2
3	170	0.5*1	3	350	2*2
4	171	1.5*1	4	362	2*3
5	354	1.5*2	5	369	2*2
6	349	1.5*2	6	304	2*3
7	207	0.5*0.5	7	206	1.5*1
8	208	0.5*1	8	207	0.5*0.5
9	209	0.5*1	9	208	0.5*1
			10	209	1*1

MagCore® Automated Nucleic Acid Kits Specification

Cartridge Code	MagCore® Super/HF16Plus/PlusII			MagCore® HF16/Compact/HF48		
	Cat No.	Cat No.	Running Time	Cat No.	Cat No.	Running Time
405	36 preps	96 preps		36 preps	96 preps	
	MGF-01	MGF-03	33min(sample volume:400µl)	MGF-01	MGF-03	175min(2-hour heating)-Standard 1012min(16-hour heating)-High Yield

Enzyme Selection Guide

Product	Contents	Cat No.
Proteinase K Set	11 mg Proteinase K, 1.25 ml PK Storage Buffer	PK011
RNase A	50 µl RNase A (50mg/ml)	RN050
	130 µl RNase A (50mg/ml)	RN130



FDA (10055336) registered and CE-IVD certified (Instruments & Reagents)
Manufactured in accordance with quality system requirements that comply with ISO 13485 standards and QSR



MagCore® Nudeic Acid Extraction Kits



For extraction of genomic DNA from forensic samples

MagCore® Genomic DNA Forensic Direct Kit is designed for purifying total DNA from forensic samples, such as dried blood spots, cigarette butts, cartilage, hair roots, seminal stains, and chorionic villus, using MagCore® auto-extraction instruments. Its unique feature is RBC patented technology that allows to isolate DNA automatically from solid samples without any pretreatment.

406

MagCore® Forensic DNA Direct Kit



Applications

It uses magnetic-particle technology to purify genomic DNA from forensic samples. The purified genomic DNA can be directly used for downstream applications such as STR, PCR and real-time PCR.

Traditional Manual Forensic DNA Extraction Method

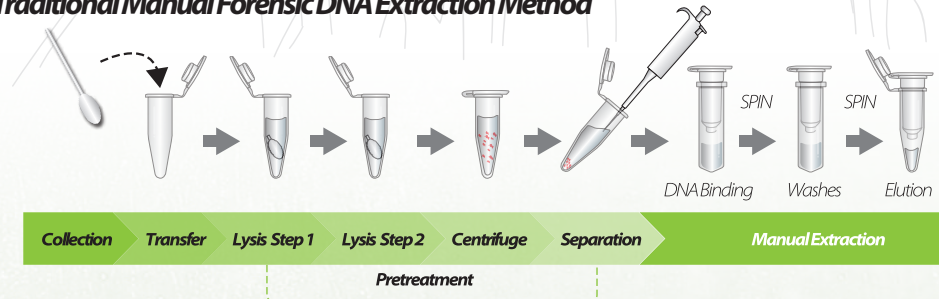

Automated Lysis and Separation

MagCore® Forensic DNA Direct Kit Method



Performance

Unique Pipette Tip Design

Novel Patented Tip

- Airtight assurance (hemetic seal)
- Minimal aerosol contamination
- Automatic separation of the solid debris

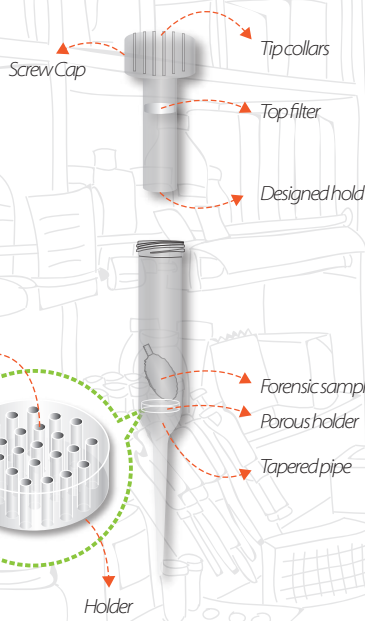

Compare the results between 406 and Q kit by qPCR

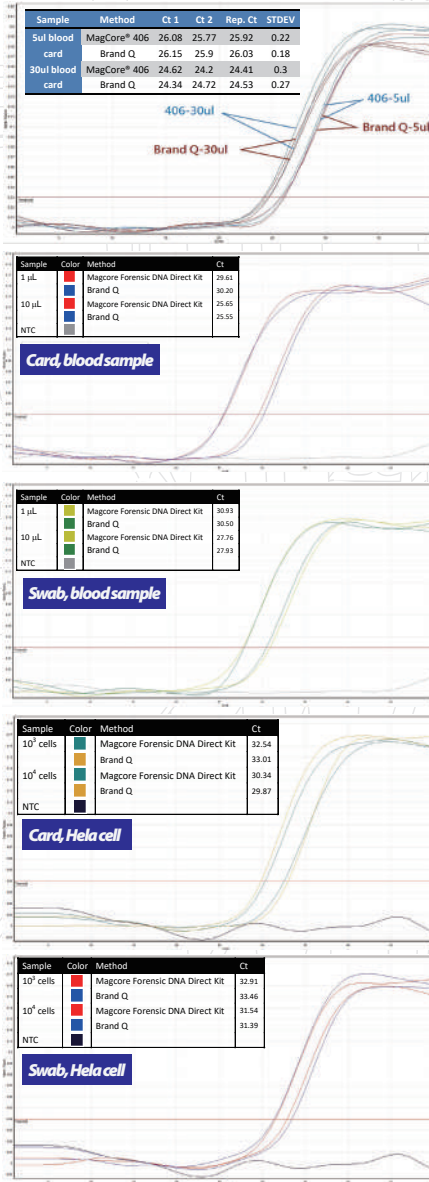

Other casework samples

Reference samples

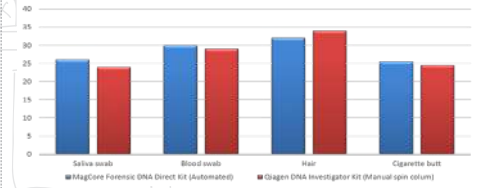

Figure: Extraction of simulated casework samples. This test was analyzed by real-time PCR with GAPDH gene primer. Saliva swab: 10 ml of saliva was applied (n=4). Blood swab: 1 ml of blood was applied and allowed to dry (n=4). Hair: 1 hair each from donor (n=4). Cigarette butt: A quarter of a filter paper (n=4).

MagCore® Automated Nucleic Acid Kits Specification

MagCore® Super/HF16 Plus/Plus II

Cartridge Code	Cat No.	Running Time
	72preps	

406

MagCore® Forensic DNA Direct Kit

For extracting genomic DNA from forensic samples

Contents: Pre-Filled Cartridges (Including Proteinase K), Disposable Tip & Holder Sets, Elution Tubes, FS Tip, 200 ml SP Tip

Shelf life: 12 months

MFC-03	120 min
--------	---------

Enzyme Selection Guide

Product	Contents	Cat. No.
Proteinase K Set	11 mg Proteinase K, 1.25 ml PK Storage Buffer	PK011
RNase A	50 µl RNase A (50mg/ml)	RN050
	130 µl RNase A (50mg/ml)	RN130



MD 757696



RBC Bioscience Corp.

www.rbcbioscience.com
info@rbcbioscience.com

FDA (10055336) registered and CE-IVD certified (Instruments & Reagents)

Manufactured in accordance with quality system requirements that comply with ISO 13485 standards and QSR

MagCore® Nucleic Acid Extraction Kits



For extraction of genomic DNA from bacteria

MagCore® Genomic DNA Bacterial Kit is designed to extract genomic DNA from Gram positive and Gram negative bacteria. The Kit contains all required reagents and labware for automated extraction using magnetic-particle technology. Reagents are supplied and pre-filled in cartridges, which can be easily loaded into the MagCore® instrument.

502

MagCore® Genomic DNA Bacterial kit



Features

1. High performance of purified DNA in downstream applications such as qPCR.
2. Cartridges are pre-filled and sealed to prevent contamination.
3. No phenol or chloroform involved.

Applications

MagCore® Genomic DNA Bacterial Kit is designed for automated DNA extraction from various sample types, including:

1. Cell cultures in suspension (up to 5×10^6 cells)
2. Biological fluids
3. Cell cultures on plate
4. Gram-positive and Gram-negative bacteria



Performance

High performance of purified bacterial DNA in real-time PCR

Well	Type	Target	Ct	Interpretation	Label
D2	Unknown	<i>H. pylori</i>	30.70	Positive	Sample A
D3	Unknown	<i>H. pylori</i>	30.52	Positive	Sample A
D4	Unknown	<i>H. pylori</i>	No Ct	Negative	Negative Ctrl
D5	Unknown	<i>H. pylori</i>	30.59	Positive	Sample A
E2	Unknown	<i>H. pylori</i>	26.73	Positive	Sample B
E3	Unknown	<i>H. pylori</i>	26.28	Positive	Sample B
E4	Unknown	<i>H. pylori</i>	26.40	Positive	Sample B

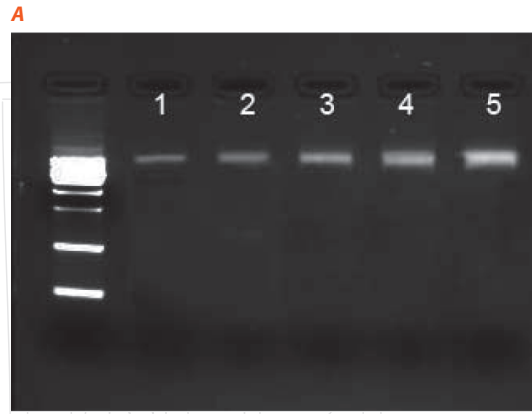
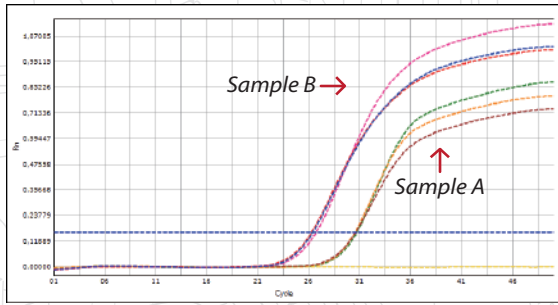

Consistent Yield, Purity, and Reproducibility in MagCore® Bacteria Genomic DNA Extraction

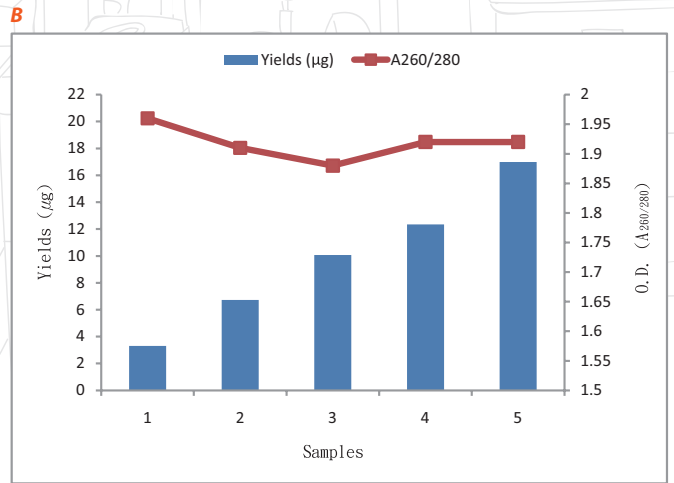

MagCore® Automated Nucleic Acid Kits Specification

Cartridge Code	MagCore® Super/HF16Plus/PlusII			MagCore® HF16/Compact/HF48		
	Cat.No.	Cat.No.	Running Time	Cat.No.	Cat.No.	Running Time
	36 preps	96 preps		36 preps	96 preps	
502	MagCore® Genomic DNA Bacterial kit					
	For 1200µl sample volumes. Contents: Pre-Filled Cartridges, Lysozyme Reaction Buffer, Proteinase K, PK Storage Buffer, Rnase A, Disposable Tip & Holder Sets, Sample Tubes, Elution Tubes Shelf life: 18 months					
	MBB-01	MBB-02	39 min (sample volume:200µl) *optical detection is not provided	MBB-01	MBB-02	44 min (sample volume:200µl)

Enzyme Selection Guide

Product	Contents	Cat. No.
Proteinase K Set	11 mg Proteinase K, 1.25 ml PK Storage Buffer	PK011
RNase A	50 µl RNase A (50mg/ml)	RN050
	130 µl RNase A (50mg/ml)	RN130



RBC Bioscience Corp.
www.rbcbioscience.com
info@rbcbioscience.com

MagCore® Nucleic Acid Extraction Kits



For extraction of microbial and host genomic DNA from stool samples

MagCore® Gut Microbiome DNA Kit is designed specifically for isolating high-quality microbial and host genomic DNA from stool and gut samples. With a short pretreatment, DNA from tough-to-lyse Gram-positive and Gram-negative bacteria which inhabit fecal samples can be successfully isolated with efficient lysis and homogenized with Beads-Beating Tube. In addition, inhibitor substances (e.g. polysaccharides, protein, etc.) commonly found in stools are removed with one-step IR Buffer. The crude DNA is then precipitated on ice and resuspended to adjust the condition that is suitable for binding genomic DNA.

Extracted DNA is ready for downstream molecular-based applications including qPCR, 16S rRNA gene sequencing, etc.

504

MagCore® Gut Microbiome DNA Kit

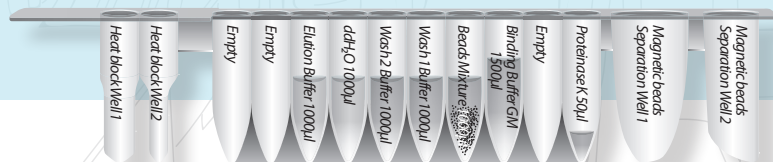

Features

1. Streamlined protocols for the isolation of inhibitor-free, PCR-quality DNA (up to 50 µg/prep) from microbes including Gram-positive and Gram-negative bacteria.
2. Hands-on time can be as little as 20 minutes.
3. Depletion of PCR inhibitors by precipitation using a novel one-step IR Buffer.
4. High-purity DNA is ready for common downstream applications such as qPCR and 16S rRNA gene sequencing.

Applications

The purified DNA can be directly used for downstream application such as:

1. qPCR
2. 16S rRNA gene Sequencing
3. Next-Generation Sequencing Applications



Performance

Stool DNA Extraction Efficiency

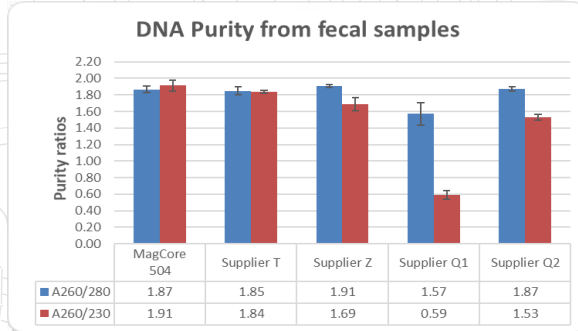
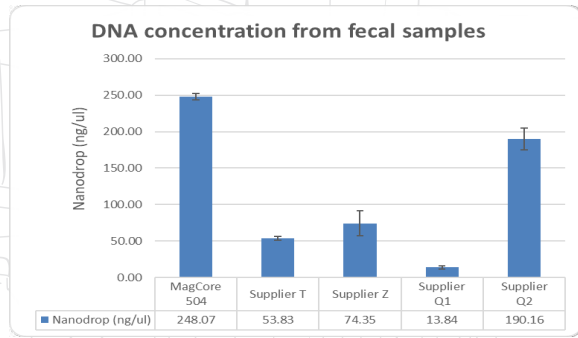

DNA was isolated from 0.2 g stool samples (in triplicates) with the MagCore Gut Microbiome DNA kit and supplier kits (supplier T, supplier Z, supplier Q1, supplier Q2). DNA concentration and purity (A260/280, A260/230) are measured by Nanodrop spectrophotometer.

Gelelectrophoresis

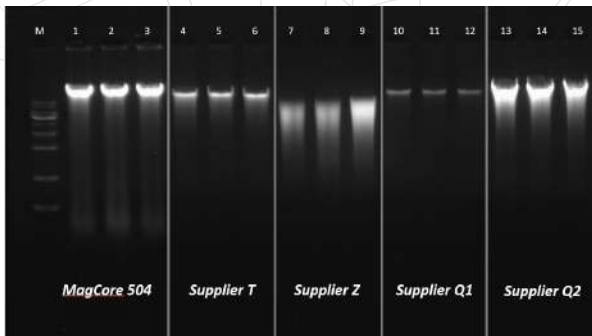

Analysis of Genomic DNA extracted from human stool samples using 1% gel electrophoresis. Performance of MagCore Gut Microbiome kit analyzed on agarose gel electrophoresis; Lane M: RBC 1 kb DNA ladder Marker.

16SrRNA gene qPCR

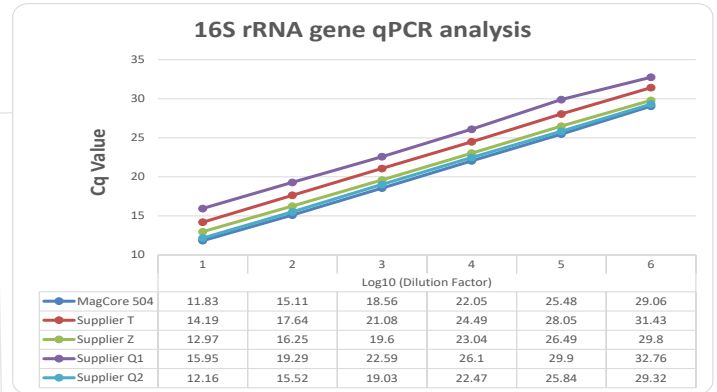

DNA extracted from stool samples using MagCore 504 kit and other competitor kits were evaluated by 10-fold serial dilution of 16S rRNA gene qPCR amplification. Non template control (NTC) was included as a reference (amplicon size: 466bp).

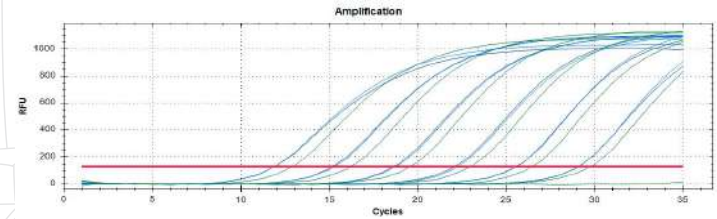

qPCR amplification curve of MagCore® 504, supplier Q2, supplier Z: MagCore 504 shows a low inhibition, similar amplification curve with supplier Q2, and superior Cq values to supplier Z.

Human fecal microbiota qPCR analysis

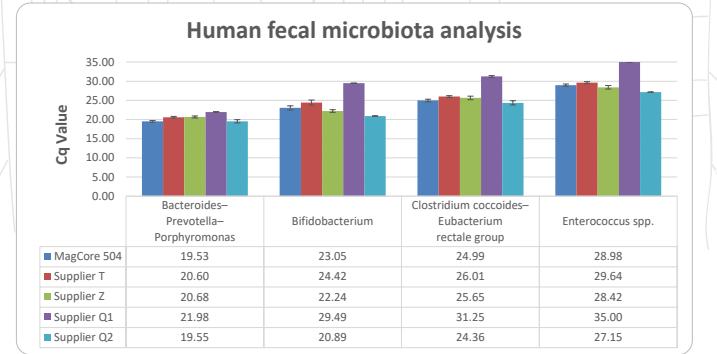

Phylum	Target organism	Gram Staining
Bacteroidetes	Bacteroides-Prevotella-Porphyromonas	G-
Actinobacteria	Bifidobacterium	G+
Actinobacteria	Clostridium coccoides-Eubacterium rectale group	G+
Firmicutes	Enterococcus spp.	G+

Human fecal microbiota qPCR analysis of four bacterial targets: Bacteroides-Prevotella-Porphyromonas, Bifidobacterium, Clostridium coccoides-Eubacterium rectale group, Enterococcus spp.. DNA from triplicate stool samples were isolated with MagCore gut microbiome DNA kit and other suppliers.

MagCore® Automated Nucleic Acid Kits Specification

Cartridge Code	MagCore® Super/HF16 Plus/Plus II			MagCore® HF16 / Compact/HF48		
	Cat.No.	Cat.No.	Running Time	Cat.No.	Cat.No.	Running Time
	24preps	72preps		-	-	
504	MagCore® Gut Microbiome DNA Kit For 200±20 mg stool sample input. Contents: Pre-filled cartridges, Beads-Beating Tube, GM-L1 Buffer, GM-L2 Buffer, GM-IR Buffer, GM-P1 Buffer, GM-P2 Buffer, GM-LY Buffer, Disposable tip & holder sets, Sample tubes, Elution tubes Shelf life: 12 months					
	MGM-01	MGM-03	MagCore® Super - 52 min MagCore® Plus II - 55 min	-	-	-



FDA (10055336) registered and CE-IVD certified (Instruments & Reagents)
Manufactured in accordance with quality system requirements that comply with ISO 13485 standards and QSR



MagCore® Nucleic Acid Extraction Kits

For extraction of total RNA from formalin-fixed paraffin- embedded (FFPE) tissue by using MagCore® System.



MagCore® Total RNA FFPE One-Step Kit is specially designed for total RNA purification from FFPE tissues by MagCore® instruments. It features the method, one-step heating, to melt paraffin without harmful reagents involved such as xylene or other organic solvents, and lyse tissues at the same time. The MagCore® Total RNA FFPE One-Step Kit System optimizes the lysis conditions to reverse the formalin fixation without the need for overnight digestion and retain both large and small RNAs. The program provides optional DNase I treatment to remove contaminated DNA.

605

MagCore® Total RNA FFPE One-Step Kit



Features

1. A full package for total RNA isolation from FFPE tissue samples. It starts from melting paraffin to the final RNA purification.
2. Highly user-friendly protocol with minimal pretreatment required.
3. Sula oil (Deparaffinization solution): no xylene or other organic solvents involved.
4. Thermostable cap is especially designed to cover the reaction well for an optimal condition where lysis buffer and the FFPE samples can mix properly during the long processing period.
5. The total processing time is within approximately 160 mins.

Applications

The purified RNA can be directly used for downstream application such as:

1. cDNA synthesis
2. real-time PCR
3. RT-PCR
4. Microarray
5. Next-Generation Sequencing

FFPE RNA extraction efficiency

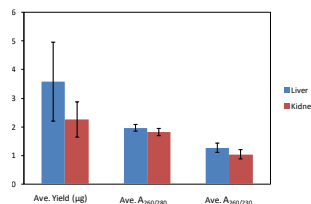

Rat tissue	Average Yields (µg)	Average A _{260/280}	Average A _{260/230}
Liver	3.57 ± 1.38	1.96 ± 0.11	1.26 ± 0.16
Kidney	2.25 ± 0.62	1.82 ± 0.12	1.03 ± 0.15

Total RNA was purified from various FFPE rat tissues stored at -80°C for 3 months. RNA yield and quality from one (liver, kidney) 50µm tissue section per sample was determined by Nanodrop n-1000.

MagCore® 605 competitors

Tissue block A

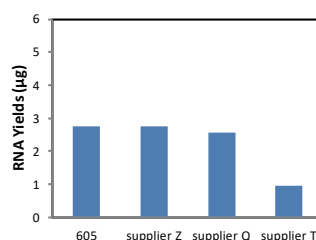

A _{260/280}	2.01	2.01	1.98	1.91
A _{260/230}	2.15	2.38	2.28	1.90

Tissue block B

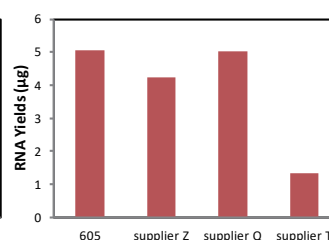

A _{260/280}	2.04	2.04	1.94	2.06
A _{260/230}	2.08	2.3	2.17	1.89

Tissue block C

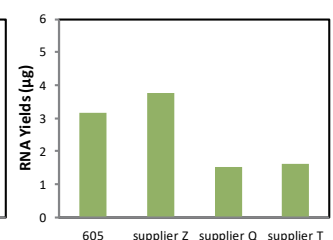

A _{260/280}	1.99	2	1.91	2.13
A _{260/230}	2.02	2.03	2.43	0.13

MagCore® 605 retains high RNA extraction efficiency in various rat liver tissue blocks compare to several FFPE RNA purification kit suppliers. The RNA yield and quality was quantified by Nanodrop n-1000.



Performance

RNA integrity

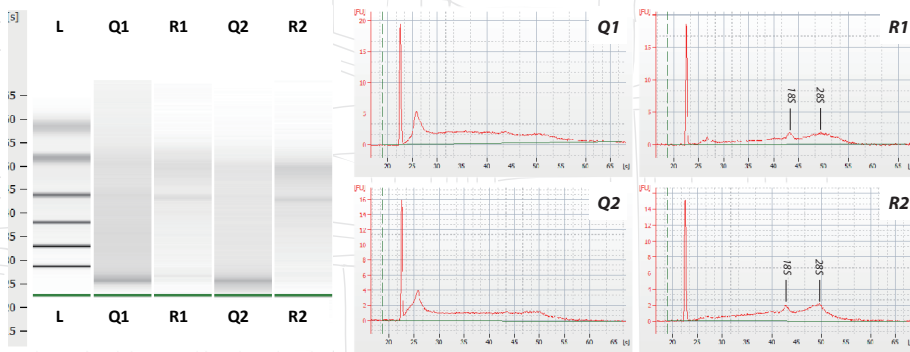

Tissue Block	Competitor Q		MagCore® 605			
	Sample	RNA yields (ng/μl)	RIN	Sample	RNA yields (ng/μl)	RIN
#1	Q1	97.37	2.2	R1	77.9	3.2
#2	Q2	58.7	2.2	R2	62.6	3.3

RNA integrity assessment

Total RNA isolation from rat liver 50μm tissue sections of FFPE tissue blocks were measured on Agilent 2100 bioanalyzer. Isolated RNA from MagCore® 605 kit maintains its integrity (18S, 28S peaks).

MagCore® 605 competitors

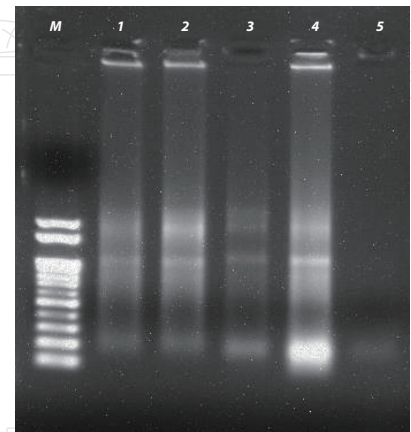

Brand	Sample	nanodrop (ng/μl)	A ₂₆₀ /280	A ₂₆₀ /230	Ct Value (GAPDH)
MagCore® 605	1	60.12	1.93	1.48	24.01
	2	74.79	1.89	1.52	22.02
Supplier Z	3	31.21	1.96	1.49	26.61
Supplier Q	4	117.54	1.93	2.17	23.75
Supplier T	5	5.89	1.46	0.15	27.39

RT-PCR performance

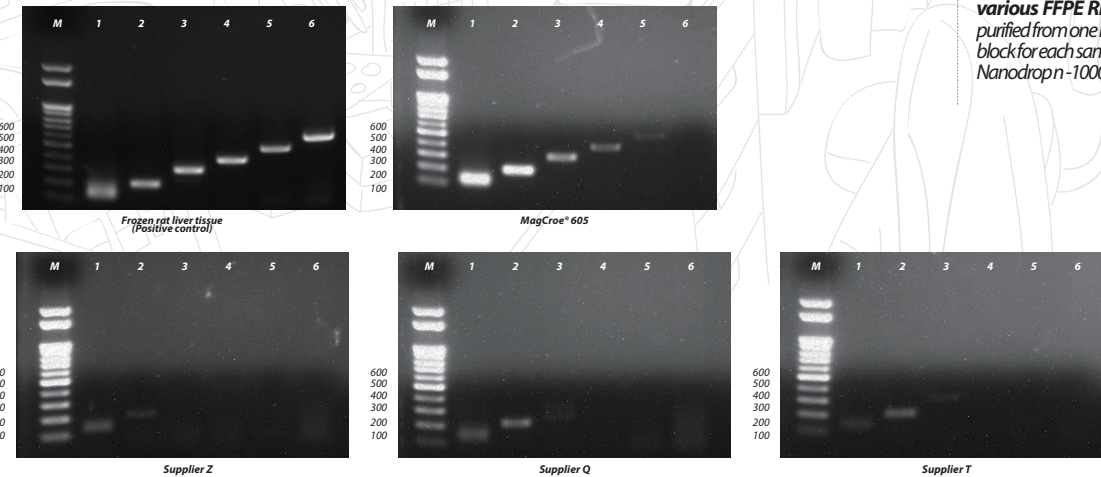

Evaluation of RNA performance in RT-PCR

Five amplicons of different length (118, 206, 312, 400, 503, 613 bp amplicon size) of the gene Rpl4 performed using cDNA derived from FFPE rat liver samples purified by various suppliers.

MagCore® Automated Nucleic Acid Kits Specification

Cartridge Code	MagCore® Super/HF16 Plus/Plus II			MagCore® HF16 /Compact		
	Cat.No.	Cat.No.	Running Time	Cat.No.	Cat.No.	Running Time
	24preps	72preps		24preps	72preps	

605

MagCore® Total RNA FFPE One-step Kit

For extraction of total RNA from formalin-fixed paraffin-embedded (FFPE) tissue by using MagCore® System.

Contents: Pre-Filled Cartridges, Disposable Tip & Holder Sets, Elution Tubes

Shelf life: 12 months

MRF-01	MRF-03	140min (without DNase I treatment) 158min (with DNase I treatment)	MRF-01	MRF-03	147min (without DNase I treatment) 165min (with DNase I treatment)
--------	--------	---	--------	--------	---

Enzyme Selection Guide

Product	Contents	Cat.No.
DNase I Set	For 36 reactions RNase-Free DNase I (Lyophilized): 1500 Kunitz units x 1 vial, 1 ml RNase-Free Water x 1, 15 ml DNase I Reaction Buffer	DN036
	For 96 reactions RNase-Free DNase I (Lyophilized): 1500 Kunitz units x 2 vial, 1 ml RNase-Free Water x 2, 30 ml DNase I Reaction Buffer	DN096



FDA (10055336) registered and CE-IVD certified (Instruments & Reagents)
Manufactured in accordance with quality system requirements that comply with ISO 13485 standards and QSR



MagCore[®] Nucleic Acid Extraction Kits



For purification of miRNA from serum and plasma

MagCore[®] Plasma miRNA Extraction kit is designed for purification of high purity microRNA from 400 μ l serum and plasma using MagCore[®] automated extraction instrument. All the kit components of plastic consumables are DNase/RNase-free pretreated, to eliminate the possibility of cross contamination.

620

MagCore[®] Plasma miRNA Extraction Kit



Features

1. Purification of miRNA from 400 μ l serum or plasma
2. RP Buffer to precipitate inhibitors
3. High performance of purified miRNA in downstream applications
4. Cartridges are pre-filled and sealed to prevent contamination

Applications

Purified RNA ready to use in downstream applications such as:

1. Next-generation sequencing (NGS)
2. Real-time RT-PCR
3. Microarray analysis
4. Biomarker discovery

Performance

High recovery of microRNA

Extraction results of microRNA isolation from 400 µl plasma from 3 different donors with an elution volume of 60 µl using MagCore Plasma miRNA Extraction kit (620) or Brand Q kit.

Analysis of microRNA by qPCR

miR-150

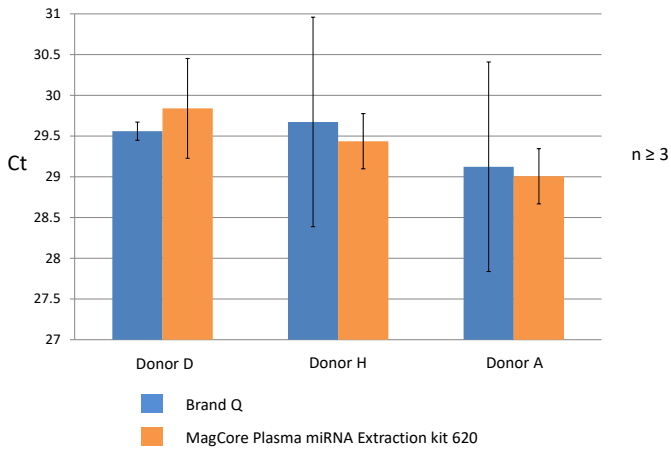

High recovery and low variance of microRNA

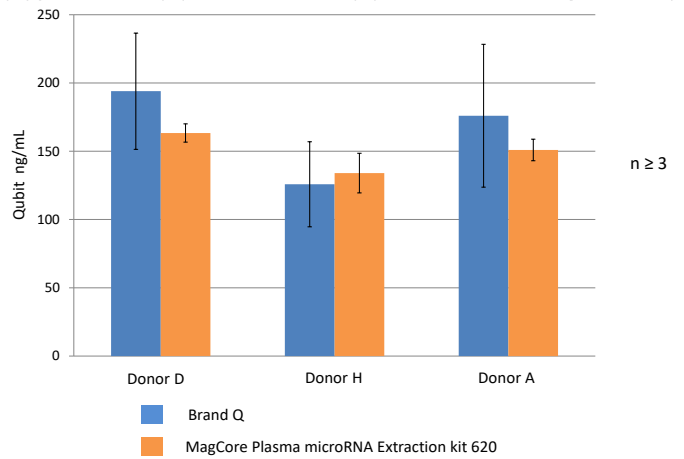

Detection of microRNAs

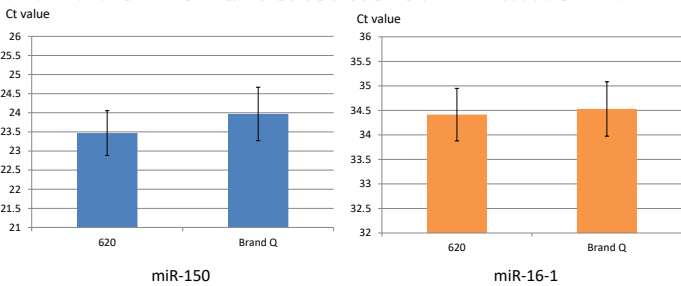

microRNA was isolated from 400 µl plasma MagCore Plasma miRNA Extraction kit (620) or Brand Q kit. miR-150 and miR-16-1 was detected by Real-Time PCR.



MagCore® Automated Nucleic Acid Kits Specification

Cartridge Code	MagCore® Super/HF16 Plus/Plus II			MagCore® HF16/Compact		
	Cat.No.	Cat.No.	Running Time	Cat.No.	Cat.No.	Running Time
620	24 preps	72 preps		24 preps	72 preps	
	MMR-01	MMR-03	40 min (without DNase I treatment) 60 min (with DNase I treatment)	MMR-01	MMR-03	34 min (without DNase I treatment) 57 min (with DNase I treatment)



FDA (10055336) registered and CE-IVD certified (Instruments & Reagents)
Manufactured in accordance with quality system requirements that comply with ISO 13485 standards and QSR



MagCore® Nucleic Acid Extraction Kits

For total RNA extraction from cultured cells, whole blood and tissues

MagCore® triXact RNA Kit is specially designed for total RNA purification from the three most common sample types in diagnostics, research, and forensics: up to 1×10^6 cultured cells, a variety of tissues, or whole blood samples. The program provides optional DNase I treatment to remove residual DNA and extract high quality DNA-free RNA. Make use of its outstanding extraction performance, efficiency, plus easy-to-follow protocols to simplify your every day extraction!



631

MagCore® triXact RNA Kit



Features

1. Excellent RNA Yield and Purity shown in both A_{260}/A_{280} ratio and RIN value
2. Highly efficient and user-friendly protocol with minimal pretreatment required
3. Capable of isolating RNA from 3 types of samples: Cells, Whole blood, Tissues
4. Optional DNase I treatment to remove residual DNA

Applications

Purified RNA ready to use in downstream applications such as:

1. PCR
2. Real-time PCR
3. Microarray target preparation
4. Northern blotting
5. NGS analysis



Performance

Total RNA from 1 x 10⁶ Hela Cell Extract

No.	Kit	nanodrop ng/μl	260/280	260/230
1	Brand Q	207.15	2.08	1.86
2		182.85	2.07	1.78
3		174.90	2.11	1.63
4	Brand Z	171.52	2.03	2.24
5		210.45	2.02	2.22
6		164.76	2.05	2.17
7	MagCore® triXact RNA Kit	264.69	2.04	2.11
8		250.61	2.02	2.17
9		237.44	2.03	2.17
10	Brand M	224.35	2.11	2.26
11		252.69	2.10	2.30
12		222.45	2.08	2.18

Table 1. Analysis of Cell RNA from MagCore® triXact Kit and others

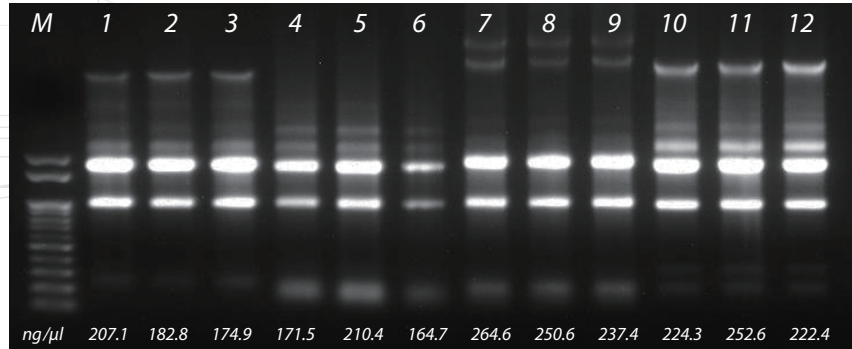

Fig 1. Gel Electrophoresis of RNA from 1 x 10⁶ Hela Cell Extract

Total RNA from 400μl Human Whole Blood

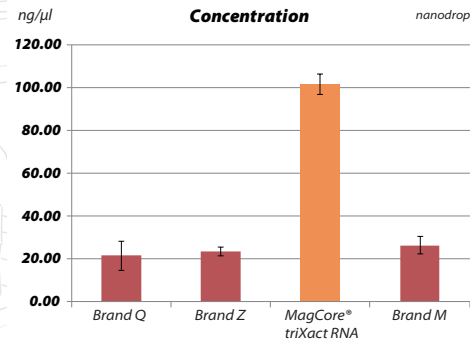

Fig 3. Concentration comparison of RNA from 400μl Human Whole Blood

No.	Kit	nanodrop ng/μl	260/280	260/230
1	Brand Q	28.77	1.99	1.69
2		20.88	2.06	0.31
3		15.02	1.89	0.85
4	Brand Z	21.36	1.97	1.82
5		23.32	1.98	1.48
6		25.50	1.71	1.26
7	MagCore® triXact RNA Kit	96.87	1.94	1.18
8		106.00	1.92	2.02
9		102.06	1.95	2.06
10	Brand M	27.03	1.91	0.73
11		22.09	2.35	1.23
12		30.13	2.08	0.37

Table 2. Analysis of Whole Blood RNA isolated by MagCore® triXact RNA Kit and others

No.	indicated anticoagulants	whole blood (ml)	nanodrop ng/μl	260/280	260/230
1	EDTA	0.4	40.08	2.03	1.69
2		0.8	189.10	1.96	2.09
3		1.2	256.82	1.94	2.12
4	Lithium Heparin	0.4	62.19	1.98	1.79
5		0.8	137.97	1.96	1.98
6		1.2	132.37	1.96	1.96
7	Sodium Citrate 3.2%	0.4	84.52	1.93	1.77
8		0.8	148.96	1.94	2.01
9		1.2	240.19	1.94	2.15
10	BD Vacutainer ACD Solution A	0.4	75.06	1.94	1.79
11		0.8	134.10	1.95	1.93
12		1.2	176.26	1.95	1.16

Table 3. Extraction efficiency of RNA from Human Whole Blood with various anticoagulants

Total RNA from 30mg Fish Tissue

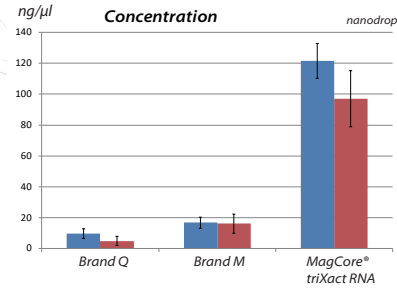

Fig 4. Concentration comparison of RNA from 30mg Fish Tissue with/without DNase I treatment



MagCore® Automated Nucleic Acid Kits Specification

Cartridge Code	MagCore® Super/HF16 Plus/Plus II			MagCore® HF16/Compact		
	Cat No.	Cat No.	Running Time	Cat No.	Cat No.	Running Time
	24preps	72preps		24preps	72preps	

631

MagCore® triXact RNA Kit

For total RNA extraction from cultured cells, human whole blood and animal tissues

Contents: Pre-Filled Cartridges, RB Buffer, RBC Lysis Buffer, Filter column Set, Disposable Tip & Holder Sets, Sample Tubes, Elution Tubes

Shelf life: 12 months

Model	Running Time (without DNase I treatment; starting volume: 400μl)	Running Time (with DNase I treatment; starting volume: 400μl)	Notes
MRX-01	48min	81min	*optical detection is not recommended
MRX-03	58min	73min	(Applicable models: HF16, Compact)

Enzyme Selection Guide

Product	Contents	Cat No.
Proteinase K Set	11 mg Proteinase K, 1.25 ml PK Storage Buffer	PK011
DNase I Set	For 36 reactions RNase-Free DNase I (Lyophilized): 1500 Kunitz units x 1 vial, 1 ml RNase-Free Water x 1, 15 ml DNase I Reaction Buffer	DN036
	For 96 reactions RNase-Free DNase I (Lyophilized): 1500 Kunitz units x 2 vial, 1 ml RNase-Free Water x 2, 30 ml DNase I Reaction Buffer	DN096



RBC Bioscience Corp.
www.rbcbioscience.com
info@rbcbioscience.com